

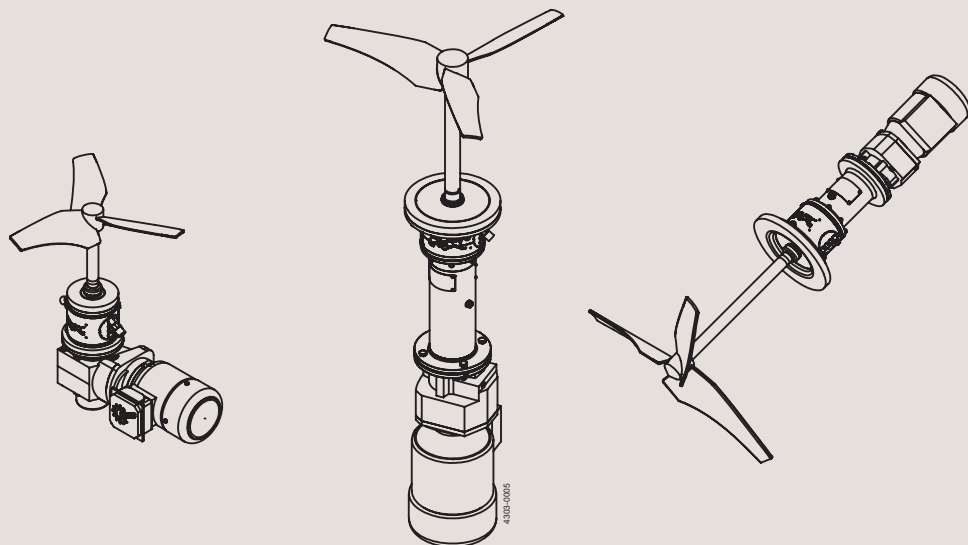

Instruction Manual

Alfa Laval Agitator - ALS / ALB



ESE03338-EN5 2020-10

Original manual



www.sks-online.com

The information herein is correct at the time of issue but may be subject to change without prior notice

1. EC Declaration of Conformity	5
2. Safety	6
2.1. Important information	6
2.2. Warning signs	6
2.3. Intended use	6
2.4. Safety precautions	7
3. Installation	8
3.1. Unpacking/delivery	8
3.2. Installation	11
3.3. Pre-use check	22
3.4. Recycling information	25
4. Operation	26
4.1. Operation/Control	26
4.2. Troubleshooting	27
4.3. Cleaning - recommendations	28
4.4. Temperature limits	28
4.5. Pressure limits	29
5. Maintenance	30
5.1. General maintenance	30
5.2. Replacement of drive unit (with bearing frame)	31
5.3. Replacement of drive unit (without bearing frame)	33
5.4. Replacement of drive unit (Motor and shaft unit)	35
5.5. Dismantling and mounting shaft (with bearing frame except BC160)	36
5.6. Replacement of bearings, type B20, B25, B25/30, B35, B35/40, B45, B45/50, B55, B55/60	38
5.7. Replacement of bearings, type BC160DH	40
5.8. Replacement of bearing, type BC160D	42
5.9. Replacement of bearings type BC160	44
5.10. Replacement of shaft seal, type D	46
5.11. Replacement of shaft seal, type DC	49
5.12. Replacement of shaft seal, type S1	52
5.13. Replacement of shaft seal, type S2	54
5.14. Replacement of shaft seal, type S3	56
6. Technical data	58
6.1. Technical data	58
6.2. Mounting angle for side mounted Agitator type ALS	58
6.3. Mounting angle for bottom mounted Agitator type ALB	59
6.4. Connecting flush – Seal type D	60
6.5. Connecting flush – Seal type DC	62
6.6. Tightening torques for bolt connections	64
6.7. Shaft alignment	65
6.8. Spider coupling	67
6.9. Storage	67
7. Parts lists and drawings, service kits and tools	68
7.1. Agitator main components, drive end	68
7.2. Agitator main components, wet end	70

Table of contents

The information herein is correct at the time of issue but may be subject to change without prior notice

7.3. Bearing frame, B20, B25, B25/30, B35, B35/40, B45, B45/50, B55, B55/60	72
7.4. Bearing frame BC160/35, BC160D/30, BC160DH/30	76
7.5. Shaft seal, type D	78
7.6. Shaft seal, type DC	80
7.7. Shaft seal, type S1	82
7.8. Shaft seal, type S2	84
7.9. Shaft seal, type S3	86
7.10. Tools	90
8. Appendix	91
8.1. Drive unit instructions	91

1 EC Declaration of Conformity

Revision of Declaration of Conformity: 2016-01-01

The Designated Company

Alfa Laval Kolding A/S

Company Name

Albuen 31, DK-6000 Kolding, Denmark

Address

+45 79 32 22 00

Phone No.

hereby declare that

Agitator - EnSaFoil

Designation

Serial number from AAC000000001 to AAC999999999

Serial number from 10.000 to 100.000

Serial number from 100700000001 to 100799999999

Serial no(s)

ALX-ME-(GX)-BC160D(H)/30(L)F-SX-SH-PXXXXYYYY
ALX-ME-(GX)-BC160/35(L)F-SX-SH-PXXXXYYYY
ALX-ME-(GX)-BXX/XX(L)F-SX-SH-PXXXXYYYY
ALX-ME-(GX)-BC160D(H)/30(L)F-D(C)-SH-PXXXXYYYY
ALX-ME-(GX)-BC160/35(L)F-D(C)-SH-PXXXXYYYY
ALX-ME-(GX)-BXX/XX(L)F-D(C)-SH-PXXXXYYYY
ALX-ME-(GX)-ZZ(L)F-SX-SH-PXXXXYYYY
ALX-ME-(GX)-ZZ(L)F-D(C)-SH-PXXXXYYYY

Type

ALX = ALB or ALS

GX = GC, GR or GP

BXX/XX = B25/30, B35, B35/40, B45, B45/50, B55, B55/60

SX = S1, S2, S3

SH = S200-S2000

PXXXX = E125, E150, E175, E200, E225, E250, E300, E350

E400, E450, E500, E550, E600, E650, E700, E750

E800, E900, E1000, E1100, E1300, E1500, E1700

E1900

YYYY = D2P, D2LP, D3P, D3LP, D2G, D2LG, D3G, D3LG

U2P, U2LP, U3P, U3LP, U2G, U2LG, U3G, U3LG

ZZ = 30, 35, 40, 45, 50, 55, 60, 65, 70, 75, 80, 90

Type variation

is in conformity with the following directives:

**Machinery Directive 2006/42/EC++
Regulation (EC) 1935/2004**

The person authorised to compile the technical file is the signer of this document

Global Product Quality Manager
Pumps, Valves, Fittings and Tank Equipment

Title

Lars Kruse Andersen

Name

Kolding
Place

2020-02-01
Date (YYYY-MM-DD)

Signature



2 Safety

Unsafe practices and other important information are emphasised in this manual.

Warnings are emphasised by means of special signs.

Always read the manual before using the Agitator!

Illustrations are only to illustrate the problem and is NOT a drawing of the current Agitator!

2.1 Important information

WARNING

Indicates that special procedures must be followed to avoid serious personal injury.

CAUTION

Indicates that special procedures must be followed to avoid damage to the Agitator!

NOTE

Indicates important information to simplify or clarify procedures.

2.2 Warning signs

General warning:



Dangerous electrical voltage:

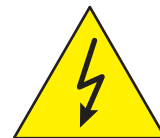

2.3 Intended use

- The Alfa Laval Agitator is only for mixing/stirring of liquids in a tank.
- The Agitator is only for mounting positions as specified on the nameplate by the first group of letters of the type designation.

ALT(B)- is for top mounting, ALS- is for side mounting and ALB- is for bottom mounting.

The exact mounting angle is specified on the Name Plate and must be followed. Definitions on mounting angles can be seen in section 6.2 Mounting angle for side mounted Agitator type ALS and section 6.3 Mounting angle for bottom mounted Agitator type ALB.

- The different duties and operation data like pressure, speed and media temperature, which the Agitator is designed for, can be found in the Alfa Laval quotation agreement¹⁾ and may not be exceeded by all means.
- If the Agitator is installed in pressurized tanks local regulations and legislations must be met.

¹⁾ The Alfa Laval quotation agreement has been exchanged during the quote process between a technical purchaser and Alfa Laval. If you are not in hold of the Alfa Laval quotation agreement, please get through to your local Alfa Laval contact, inform the Agitator serial number and article number which is stated on the Name Plate and you will obtain the Alfa Laval quotation agreement.

All warnings in the manual are summarised on this page.

Pay special attention to the instructions below so that severe personal injury and/or damage to the Agitator are avoided.

2.4 Safety precautions

Installation:

Always read the technical data thoroughly (see chapter 6 Technical data).

Always follow installation instructions thoroughly (see chapter 3 Installation).

Never expose the Agitator to undue vibrations or shocks.

Never start Agitator in the wrong rotation direction.

Ensure that the tank media is not corrosive to the Agitator.

Only install the Agitator in environments within temperature limit: -20°C and +40°C.

Only install the Agitator in altitudes less than 1000 m above sea level.



Never touch the moving parts while the Agitator is connected to the power supply.



Operation:

Always read the technical data thoroughly (see chapter 6 Technical data).

Always read supplier instructions thoroughly (see chapter 8 Appendix).

Never start Agitator in the wrong rotation direction.

Always rinse well with clean water after cleaning.

Beware of temperature limitations.

Beware of Agitator in operation can produce sound levels in excess of 85dB(A).

Never operate continuously within 20% of critical oscillation speed (see chapter 6 Technical data).



Never touch the moving parts while the Agitator is connected to the power supply.



Maintenance:

Always read the technical data thoroughly (see chapter 6 Technical data).

Always follow the maintenance instruction thoroughly (see chapter 5 Maintenance).

Always follow the maintenance instruction from drive unit supplier (see chapter 8 Appendix).

Always study the parts list and assembly drawing carefully (see chapter 7 Parts lists and drawings, service kits and tools).



Never touch the moving parts while the Agitator is connected to the power supply.

Always disconnect the power supply while servicing the Agitator.



Ensure correct rotation direction of impeller before startup and after any maintains there might have impact on the direction.

Transportation:

Always transport the Agitator in original packaging.

Always support the shaft adequately, to protect shaft and bearings.

Never expose the Agitator to undue vibrations or shocks.

Control for oil leakage on gears with vent screw.

3 Installation

The instructions manual is part of the delivery.
Study the instructions carefully

3.1 Unpacking/delivery



Always use lifting equipment when handling the Agitator (see Step 3).

CAUTION

Alfa Laval cannot be held responsible for incorrect unpacking.
Alfa Laval cannot be held responsible for incorrect unpacking.

Step 1

Inspect the delivery for visible transportation damages - all issues to be reported to carrier.

Step 2

Check the delivery for:

1. Complete Agitator
2. Nameplate designations
3. Delivery note
4. Separate instruction manuals from suppliers (see chapter 8 Appendix).

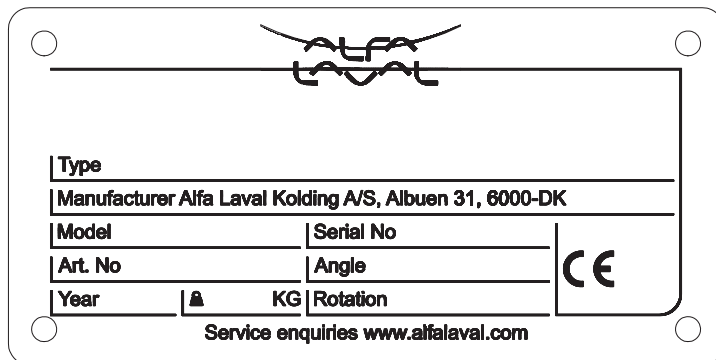

Step 3

Lifting instructions:



Always use the correct lifting equipment (see Agitator weight on name plate).
Locate Centre of gravity before moving the Agitator.

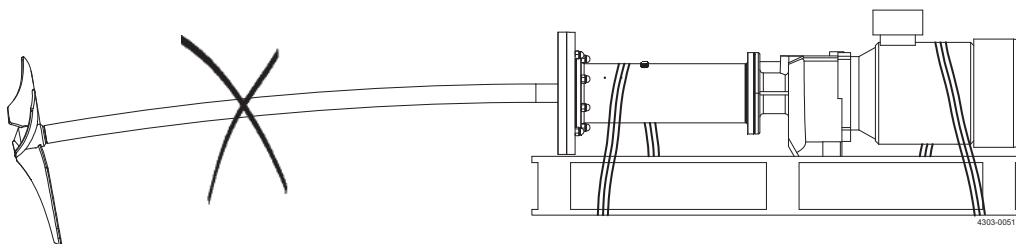

The instructions manual is part of the delivery.
Study the instructions carefully

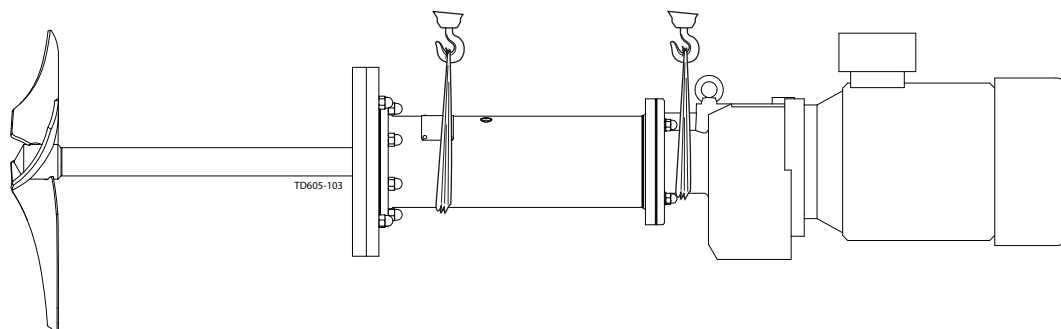

WARNING

Do NOT use eye bolts on gear motor to lift the Agitator. They are only for gear motor removal.

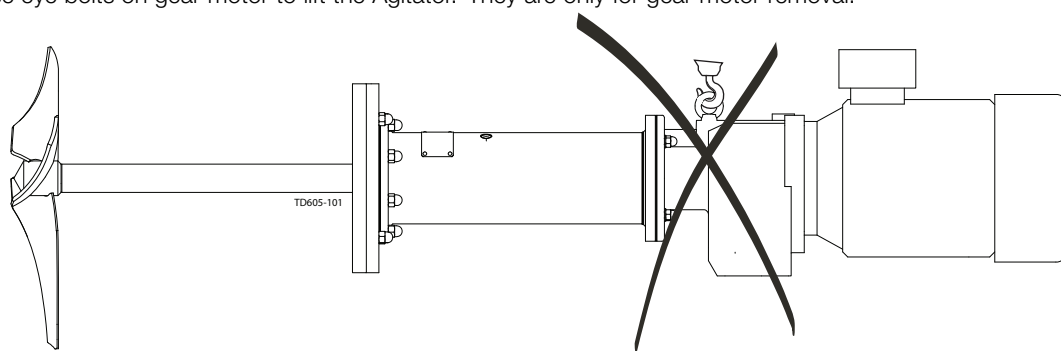

WARNING

Do NOT use eye bolts on shroud (if any) to lift the Agitator.
They are only for shroud removal.

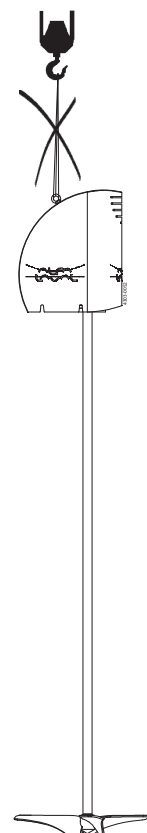

3 Installation

*The instructions manual is part of the delivery.
Study the instructions carefully*

CAUTION

Alfa Laval recommends **NOT** to use shaft as lifting point but long shafts must be supported adequately during lifting to protect shaft, bearings and seals arrangements.
Gear motor / motor may be used for lifting the assembled Agitator.

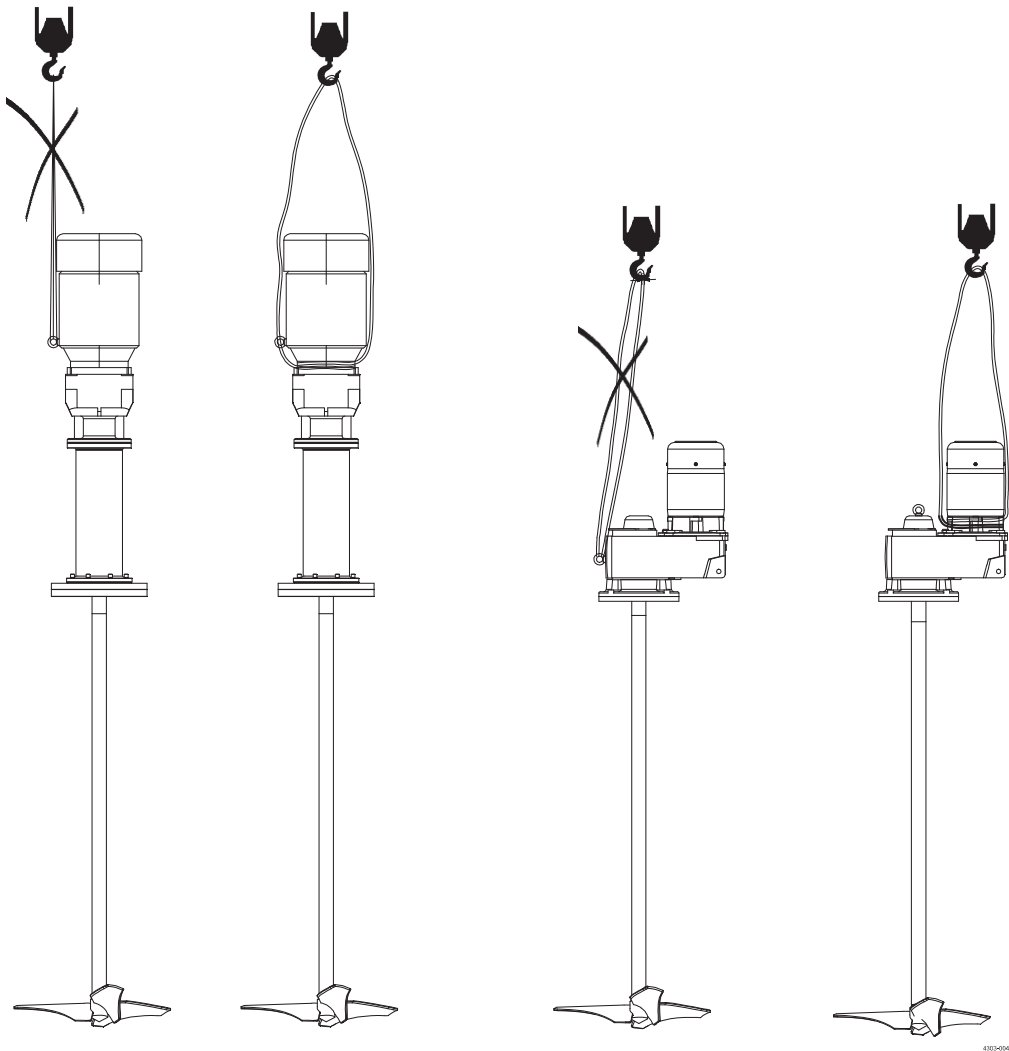

Step 4 During transportation



1. **Always** support the shaft adequately, to protect shaft and bearings.
2. **Never** expose the Agitator to undue vibrations or shocks.
3. Control for oil leakage on gears with vent screw.

Study the instructions carefully and pay special attention to the warnings!
Always check the Agitator before operation - see chapter 3.3 Pre-use check.
The Agitator is for permanent fastening.
Make sure that the motor correspond to the environment.

3.2 Installation



Always read the technical data thoroughly (see chapter 6 Technical data).
Only install this Agitator in mounting angle according to the name plate (see chapter 6 Technical data).
Always use lifting equipment when handling the Agitator (see Step 2).
Always have safety elements removed by authorized personnel.
Never cover or remove the nameplate.



Never connect to power supply during installation or service.
Always have the Agitator connected to power supply by authorized personnel.

NOTE

Alfa Laval highly recommend to install motor protection guard to protect the motor from overloading.
Never install a none Alfa Laval shroud on the Agitator as it can lead to overheat and a breakdown of the motor.

Welding flange:

CAUTION

Only authorized personnel to weld in flanges.
Alfa Laval cannot be held responsible for incorrect installation.

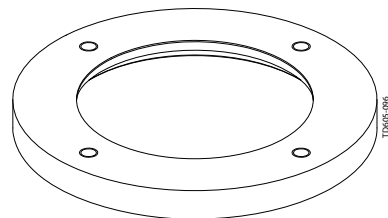

Step 1

Dismantle the welding flange if fitted onto the Agitator.

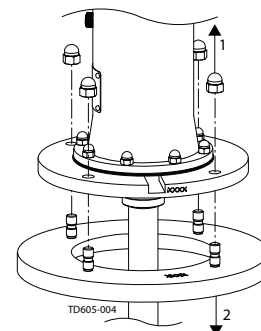

3 Installation

Study the instructions carefully and pay special attention to the warnings!
 Always check the Agitator before operation - see chapter 3.3 Pre-use check.
 The Agitator is for permanent fastening.
 Make sure that the motor correspond to the environment.

Step 2

Ensure that the tank, where the welding flange are to be welded in, can handle the forces applied by the Agitator: Torque M_v , Bending torque M_b and Side thrust F_s .

The values are depending on the Agitator configuration. The following information is required to calculate the forces:

P: Power of the motor in [kW]

n: Speed of Agitator shaft [RPM]

S: Shaft length according to Agitator type designation -Sxxxx- in [mm]

D: Largest impeller diameter according to Agitator designation -Pxxx- in [mm]

The values can be calculated as follows:

Type ALS/ALB:

$$M_v \text{ [Nm]} = 23873 \times P / n$$

$$F_s \text{ [N]} = 4.5 \times M_v \times 1000 / D$$

$$M_b \text{ [Nm]} = F_s \times S / 1000$$

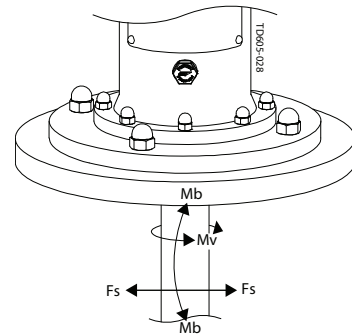

Step 3

During the design phase of the tank, ensure sufficiently rigidity of the tank.

Ensure that the max. bending angle (A°), at loads from Step 2 does not exceed according to below scheme

RPM:	<100	>100
A° (max bending angle at applied loads):	0.1	0.05

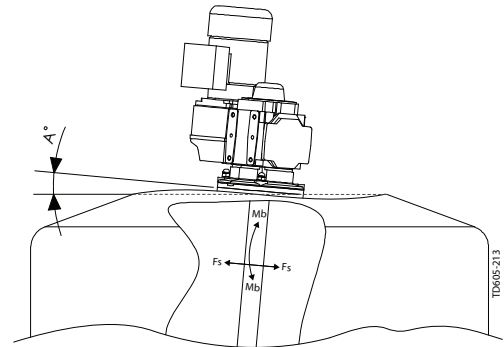

*Study the instructions carefully and pay special attention to the warnings!
Always check the Agitator before operation - see chapter 3.3 Pre-use check.
The Agitator is for permanent fastening.
Make sure that the motor correspond to the environment.*

Guidelines for installing Flat Shaped Welding Flange (FSWF), ALS Agitator:

(for mounting flange without nose)

CAUTION

Alfa Laval recommend that all other welding tasks on the tank are finished before installing welding flange in tank.

ALS Agitator must be installed in the tank as shown in chapter 6.2 Mounting angle for side mounted Agitator type ALS which can be achieved as shown on the illustration below.

1. Tank wall
2. Cone for welding flange
3. Welding flange

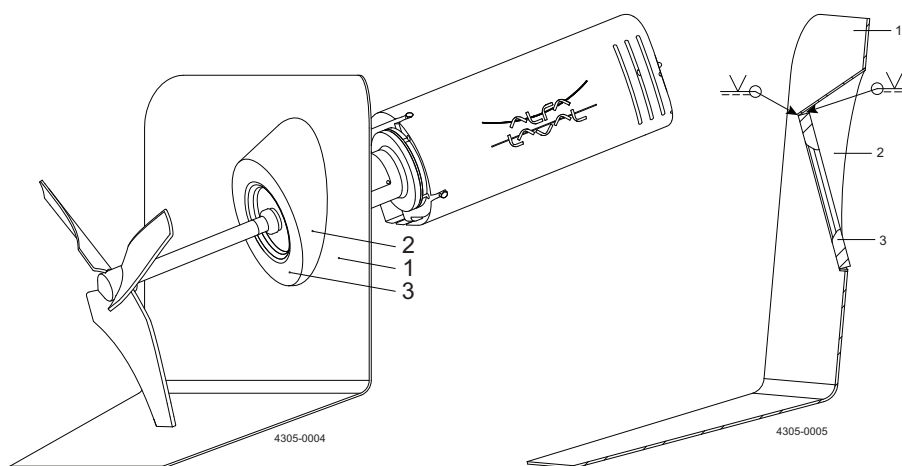

3 Installation

Study the instructions carefully and pay special attention to the warnings!
Always check the Agitator before operation - see chapter 3.3 Pre-use check.
The Agitator is for permanent fastening.
Make sure that the motor correspond to the environment.

Guidelines for installing Flat Shaped Welding Flange (FSWF), ALB Agitator:

(for mounting flange with nose)

CAUTION

Alfa Laval recommend that all other welding tasks on the tank are finished before installing welding flange in tank.

ALB Agitator must be installed in the tank as shown in chapter 6.3 Mounting angle for bottom mounted Agitator type ALB which can be achieved as shown on the illustration below.

In case of installation of Welding Flange parallel to tank bottom surface (shaft perpendicular to tank bottom surface) it is always recommended to use a bead/cone. This is to ensure that tank bottom stresses / forces are not transmitted directly to the Welding Flange increasing the risk of leakages.

1. Tank bottom
2. Cone for welding flange
3. Welding flange

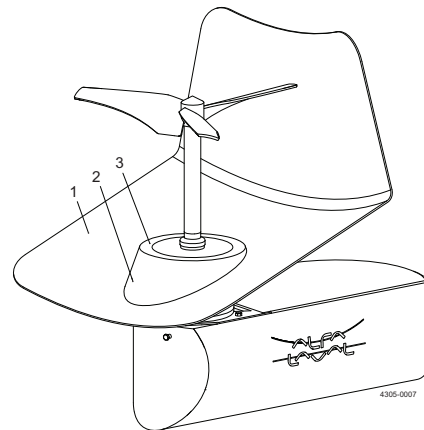

1. Tank bottom
2. Cone for welding flange
3. Welding flange
4. Weldings

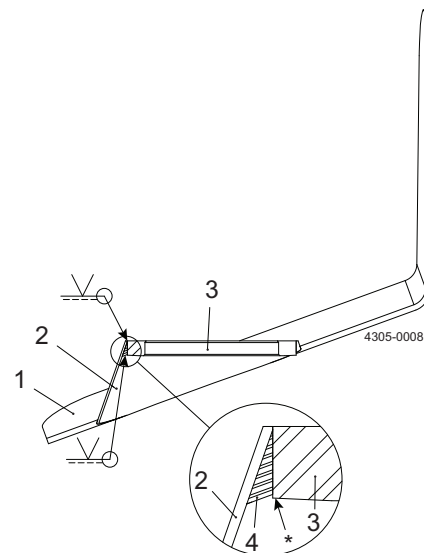

CAUTION

Ensure that no weldings are applied to the outside surface of the welding flange* as the Agitators mounting flange has the same size as the welding flange. If weldings by mistake are applied to the surface of the welding flange it must be removed by grinding, or the like, to ensure a correct fit and installation of the mounting flange.

Study the instructions carefully and pay special attention to the warnings!
 Always check the Agitator before operation - see chapter 3.3 Pre-use check.
 The Agitator is for permanent fastening.
 Make sure that the motor correspond to the environment.

Welding procedure FSWF, ALS Agitator:

(for mounting flange without nose)

Step 1

Always allow flange to cool to ambient temperature after each section has been welded
 Position the flange correctly

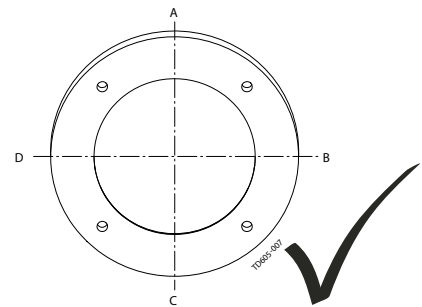
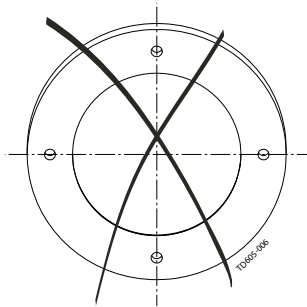

Step 2

Spot weld from outside.

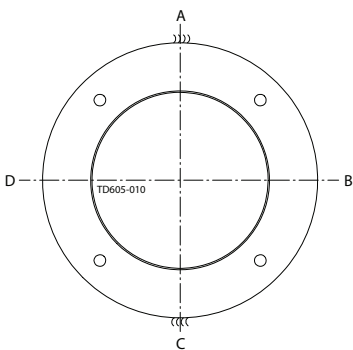

Adjust alignment!

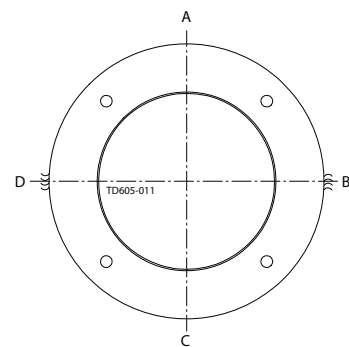

Step 3

Weld the following sections first from outside then from inside, and cool with air between each section.

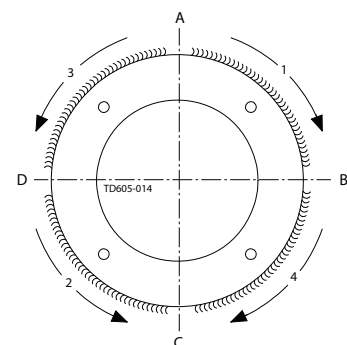

3 Installation

Study the instructions carefully and pay special attention to the warnings!
Always check the Agitator before operation - see chapter 3.3 Pre-use check.
The Agitator is for permanent fastening.
Make sure that the motor correspond to the environment.

Step 4

Ensure that the surface flatness tolerance equals 0,25 after welding.
Grind and polish the welding flange.
Use a solid straight ruler and a feeler gauge to determine the flatness.

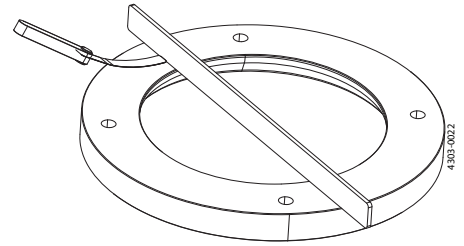

Study the instructions carefully and pay special attention to the warnings!
 Always check the Agitator before operation - see chapter 3.3 Pre-use check.
 The Agitator is for permanent fastening.
 Make sure that the motor correspond to the environment.

Welding procedure FSWF, ALB Agitator:

(for mounting flange with nose)

NOTE

Alfa Laval recommend a welding tool with, if possible, build in cooling by flowing water, to be made and fixed to the FSWF to ensure shape and form of the FSWF during welding and installation.
 In general Alfa Laval recommend to weld the welding flange onto a bended rim of the tank bottom plate – this is to secure adequate flexibility at high loads, e.g. when the tank is filled. If a bended rim is impossible to obtain due to a high plate thickness, Alfa Laval recommend to weld the welding flange onto a cone shaped plate section.
 If not following the above recommendations there will be a risk that the flange can deform, especially at high tank fillings, which can cause a leakage between the welding flange and the Agitator mounting flange.

Step 1

Position the flange correctly.

Always allow flange to cool to ambient temperature after each section has been welded.

Step 2

Spot weld from outside.

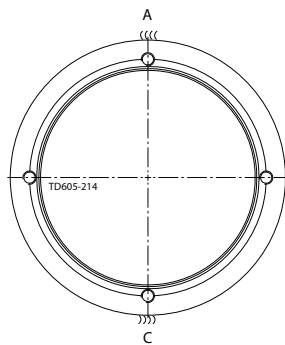

Adjust alignment!

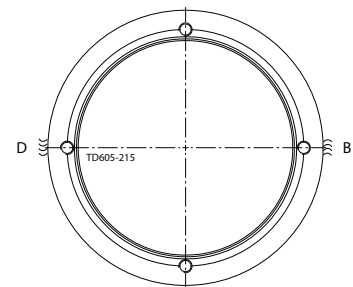

Step 3

Spot weld from inside

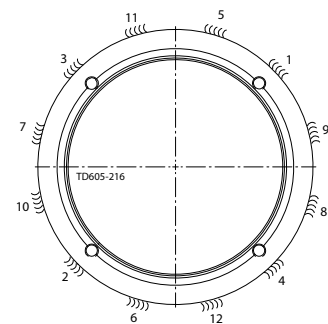

3 Installation

*Study the instructions carefully and pay special attention to the warnings!
Always check the Agitator before operation - see chapter 3.3 Pre-use check.
The Agitator is for permanent fastening.
Make sure that the motor correspond to the environment.*

Step 4

Weld the following sections first from inside then from outside and cool to ambient temperature after each section has been welded

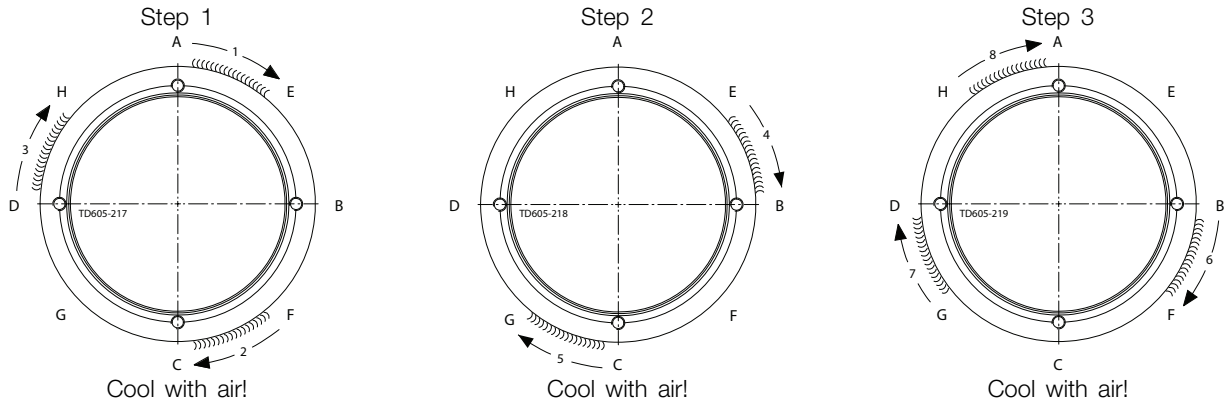

Step 5

Remove the welding tool.
Ensure that the surface flatness tolerance equals $\pm 0.1\text{mm}$.
Grind and polish the welding flange.

Study the instructions carefully and pay special attention to the warnings!
Always check the Agitator before operation - see chapter 3.3 Pre-use check.
The Agitator is for permanent fastening.
Make sure that the motor correspond to the environment.

Mounting Agitator:

CAUTION

Always ensure that mounting is carried out according to description shown in chapter 6.2 Mounting angle for side mounted Agitator type ALS and chapter 6.3 Mounting angle for bottom mounted Agitator type ALB.
Always refer to tightening torques in chapter 6.6 Tightening torques for bolt connections when tightening bolts.

Step 1

Place impeller device(s) in the tank.

Ensure that tank and Agitator surfaces are clean.

Ensure that drain (I) is pointing downwards.

For gears with vent screw, ensure the vent is pointing upwards and the rubber plug (III) is removed (see chapter 8.1 Drive unit instructions).

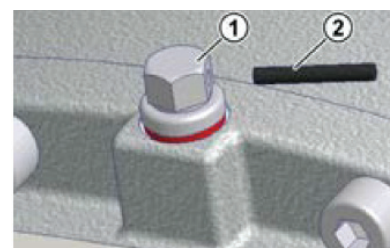
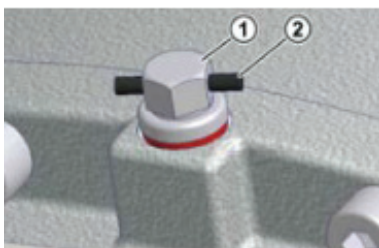
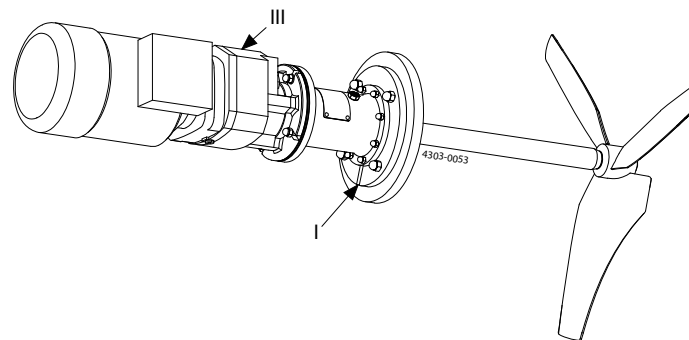

- 1) Standard vent plug
- 2) Transport securing device

Step 2

Mount the Agitator onto the tank.

3 Installation

Study the instructions carefully and pay special attention to the warnings!
 Always check the Agitator before operation - see chapter 3.3 Pre-use check.
 The Agitator is for permanent fastening.
 Make sure that the motor correspond to the environment.

Step 3

Mount impeller device(s) onto shaft.

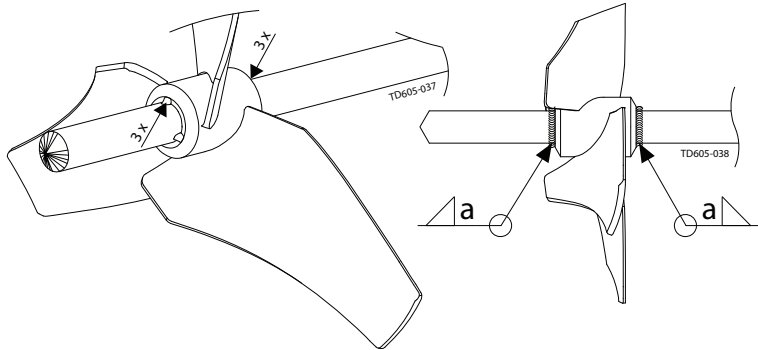

Hub diameter [mm]	a - dimension [mm]
Ø30	1,1
Ø40	1,8
Ø55, Ø80, Ø120	2,8

All-weld propeller to shaft with one welding seam at a time, cool with air and continue with one welding until welding is according to illustration. Use welding procedures which introduce as less heat, tension and bending to the shaft as possible.

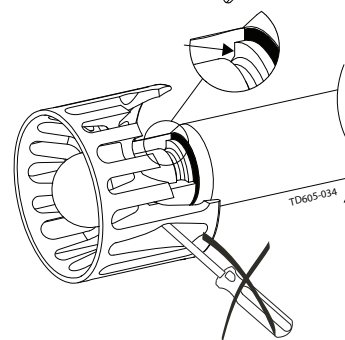
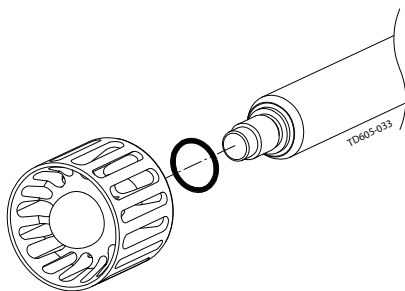
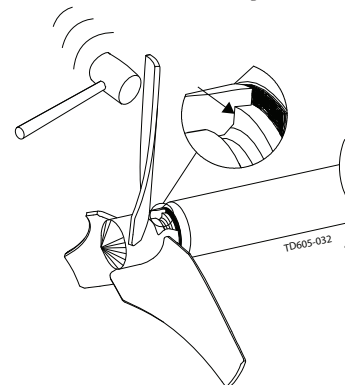
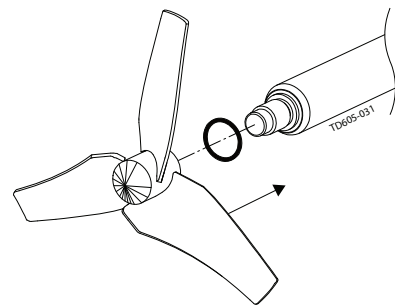
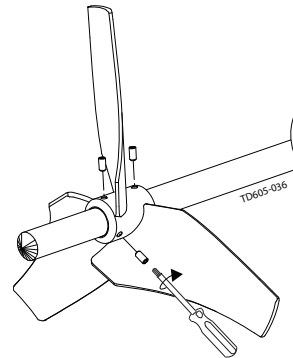
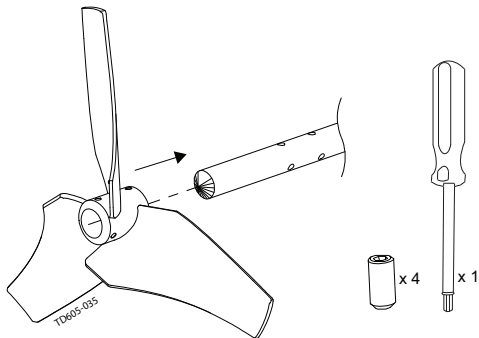

Study the instructions carefully and pay special attention to the warnings!
Always check the Agitator before operation - see chapter 3.3 Pre-use check.
The Agitator is for permanent fastening.
Make sure that the motor correspond to the environment.

Step 4

Ensure the impeller device orientation is correct according to the direction of the desired flow. The direction is determined by the letter "D" or "U" in the last part of the Agitator type description. E.g. -E400D3P has the letter "D" which means the flow direction is away from the drive unit. -E400U3P has the letter "U" which means the flow direction is towards the drive unit.

Step 5

Ensure the impeller is positioned, keeping minimum radial distance to the tank.

Further installation requirements regarding the position can be found in chapter 6.2 Mounting angle for side mounted Agitator type ALS and chapter 6.3 Mounting angle for bottom mounted Agitator type ALB to ensure optimum performance.

Clearance > $S/15$
and
Clearance > 20mm

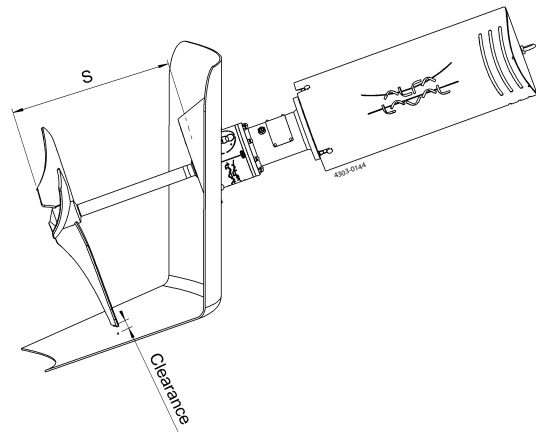

Step 6

If propellers has been all-welded to the shaft (not if it has been all-welded to the shaft-end) it can be necessary to align the shaft, using heat and or bending forces according to specifications and instructions in chapter 6.7 Shaft alignment.

WARNING

CAUTION

Do **NOT** connect the power supply until installation is completed.
Follow instructions in chapter 8.1 Drive unit instructions.
Ensure that the rotation direction is according to nameplate.
Always perform pre-use check before operation (see chapter 3.3 Pre-use check).

NOTE

On closed tanks, Alfa Laval recommends installing a manhole circuit breaker, cutting power supply if hatch is open.

3 Installation

Study the instructions carefully and pay special attention to the warnings! Always check the Agitator before operation. The Agitator is only designed to operate according to data given in chapter 2.3 Intended use, 6.2 Mounting angle for side mounted Agitator type ALS and 6.3 Mounting angle for bottom mounted Agitator type ALB. Check the rotation direction before operation.

3.3 Pre-use check



Never install the Agitator in environments which deviate from those given in chapter 2.3 Intended use and 6 Technical data.
Always ensure that all alignment specifications given in chapter 6.7 Shaft alignment are followed.
Always make sure that the motor corresponds to the environment.

Step 1

Go through chapter 2.4 Safety precautions.

Step 2

Check the fastenings.

Step 3

Check o-ring and impeller are correctly fitted.

Step 4

Check impellers CANNOT collide with tank vessel at any point during a full rotation.

Clearance > $S/15$

and

Clearance > 20mm

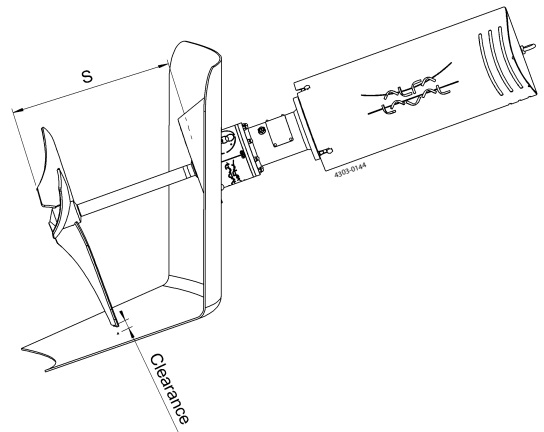

Step 5

Seal type S1, S2, S3

- Ensure the sealing surfaces are not stuck together, by slowly turning shaft by hand.
- Ensure that the seal is always submerged during operation.

NOTE

Dry running will damage the seal faces.

3 Installation

Study the instructions carefully and pay special attention to the warnings! Always check the Agitator before operation. The Agitator is only designed to operate according to data given in chapter 2.3 Intended use, 6.2 Mounting angle for side mounted Agitator type ALS and 6.3 Mounting angle for bottom mounted Agitator type ALB. Check the rotation direction before operation.

Step 6

Seal Type D

Ensure the sealing surfaces are not stuck together, by slowly turning shaft by hand.

Ensure that the seal never runs dry.

Ensure flush connections are installed in such way that air pockets are avoided.

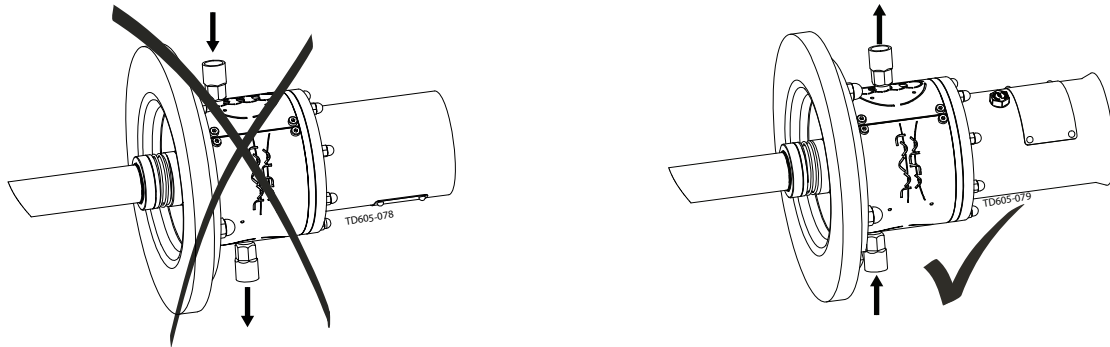

Step 7

Seal Type DC

Ensure the sealing surfaces are not stuck together, by slowly turning shaft by hand.

Ensure that the seal never runs dry.

Ensure flush connections are installed in such way that air pockets are avoided.

Ensure that the distance pieces (1) on the seal are mounted as shown on illustration.

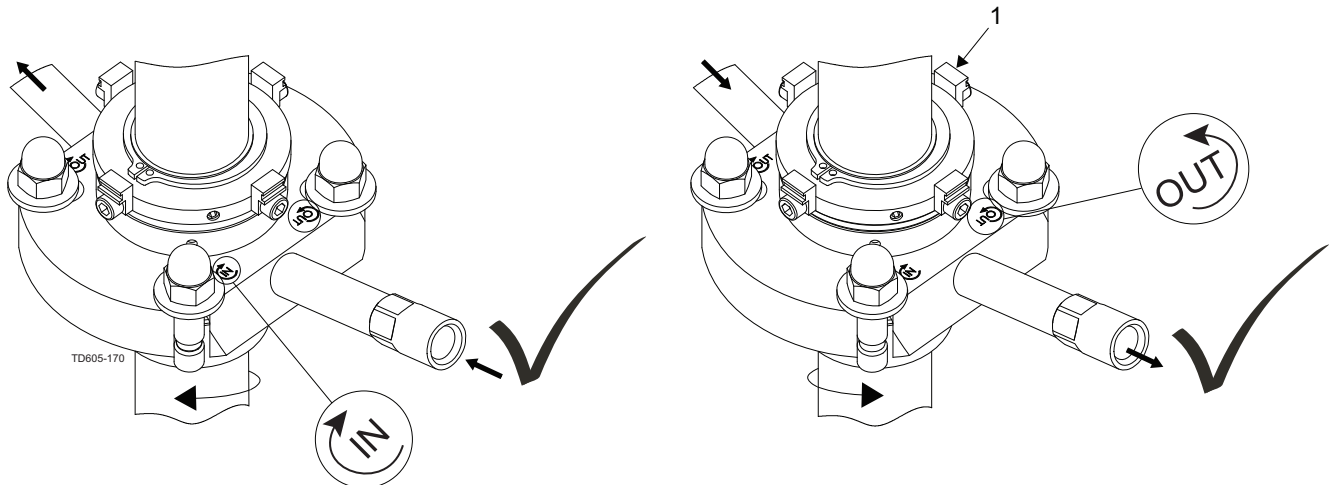

3 Installation

Study the instructions carefully and pay special attention to the warnings! Always check the Agitator before operation. The Agitator is only designed to operate according to data given in chapter 2.3 Intended use, 6.2 Mounting angle for side mounted Agitator type ALS and 6.3 Mounting angle for bottom mounted Agitator type ALB. Check the rotation direction before operation.

Step 8

Ensure that drain (I) is pointing downwards.

For gears with vent screw, ensure the vent is pointing upwards and the rubber plug (III) is removed (see chapter 8.1 Drive unit instructions and mounting instructions in Step 1 on page 19).

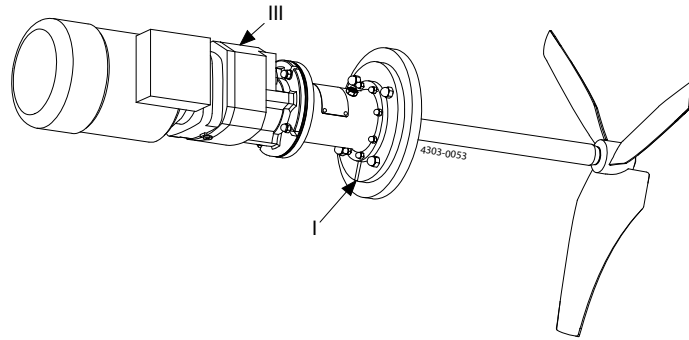

Step 9

(Only for Agitators with bearing frame)

Ensure that the PreVent valve is refitted in the bearing frame.

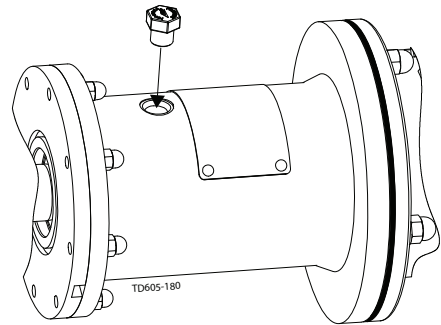

Step 10

Ensure that the rotation direction is according to nameplate, before starting the Agitator.

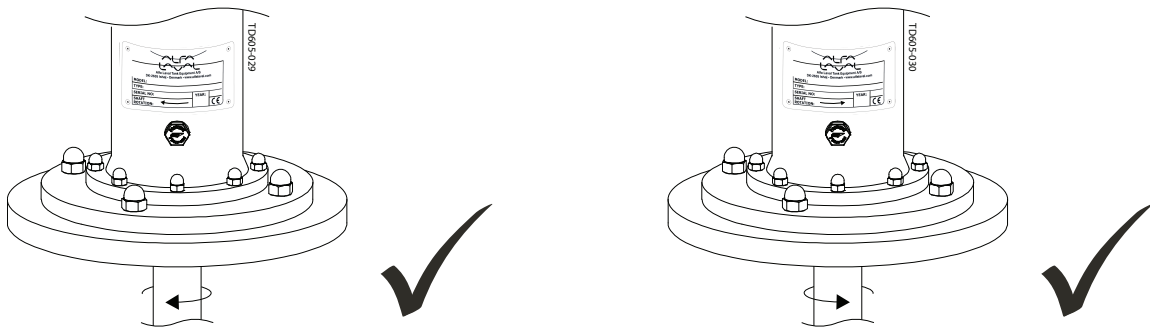

Step 11

If frequency converter drive is used, it must be ensured NOT to operate continuously within +/-20% of critical oscillation speed (see chapter 2.3 Intended use and 6 Technical data).

Step 12

Alfa Laval recommend a soft starter or a frequency converter for the Agitator to reduce the load on tank and Agitator. For operation instructions from suppliers see 8 Appendix.

The ramp up and ramp down time should be about 2-5 seconds.

3.4 Recycling information

- **Unpacking**

- Packing material consists of wood, plastics, cardboard boxes and in some cases metal straps.
- Wood and cardboard boxes can be re-used, recycled or used for energy recovery.
- Plastics should be recycled or burnt at a licensed waste incineration plant.
- Metal straps should be sent for material recycling.

- **Maintenance**

- During maintenance, oil and wear parts in the machine are replaced.
- All metal parts should be sent for material recycling.
- Worn out or defective electronic parts should be sent to a licensed handler for material recycling.
- Oil and all non-metal wear parts must be disposed of in accordance with local regulations.

- **Scrapping**

- At the end of use, the equipment must be recycled according to the relevant, local regulations. Besides the equipment itself, any hazardous residues from the process liquid must be considered and dealt with in a proper manner. When in doubt, or in the absence of local regulations, please contact your local Alfa Laval sales company.
-

4 Operation

Study the instructions carefully and pay special attention to warnings! **Always** check the Agitator before operation (see chapter 3.3 Pre-use check).

Alfa Laval recommend a soft starter or a frequency converter for the Agitator to reduce the load on tank and Agitator. For operation instructions from suppliers (see chapter 8 Appendix).

4.1 Operation/Control



If deviation from normal operation and intended use shown in chapter 2.3 Intended use, immediately switch off the Agitator and find the cause of failure (see chapter 4.2 Troubleshooting).
The Agitator is designed to max 5 starts per hour.

Inspect the Agitator regularly

	Inspect / Clean / Lubricate			
	Supplier instruction	Weekly	Monthly	Half-yearly
Drive unit				
Motor	x			
- Clean surfaces - to avoid overheating		x		
Gear	x			
- Clean vent screw (if any)		x		
- Check for oil leakage		x		
Flange				
Clean drain			x	
Sealing				
Mechanical seal				
- NOT flushed: S1, S2, S3			x	
- Flushed: DC, D			x	
Bearing frame				
Clean PreVent screw		x		
Check spider clearance				x
Check gaskets				x
Lubricate radial seals				x
Impeller device				
Sticky media				
- Clean impeller device			x	
Abrasive media				
- Check blade thickness*			x	
Check fastening of pointed set screws			x	

* If any suspicion of reduction in blade thickness, contact Alfa Laval and inform serial no stated on the name plate.

Study the instructions carefully and pay special attention to warnings! **Always** check the Agitator before operation (see chapter 3.3 Pre-use check).

Alfa Laval recommend a soft starter or a frequency converter for the Agitator to reduce the load on tank and Agitator. For operation instructions from suppliers (see chapter 8 Appendix).

4.2 Troubleshooting

Problem	Cause/result	Remedy
Not starting		
Drive unit	- Defect - Fault at power supply	Dismantle drive unit, check for correct rotation. Replace drive unit Check power supply connection Check voltage and frequency correspond with name plate Check frequency converter adjustment correspond to name plate
Agitator Bearing frame	- Obstructed	Check Agitator can rotate freely without striking anything Ensure that retainer bolt has been removed
Vibrations		
Impeller device	- Damaged - Unbalanced impeller - Damage to shaft seal	Contact Alfa Laval Clean impeller device Replace sealing
Shaft	- Damaged	Contact Alfa Laval
Other	- Deviation from normal operation - Increased / decreased temperature	Operation circumstances must equal to those it was designed for ¹⁾
Unusual noise		
Bearing frame	- Bearing gap - Wear or damaged bearings	Replace bearings and all gaskets in bearing frame immediately Replace bearings and all gaskets in bearing frame
Drive unit	- Defect - Bearing gap - Increased / decreased power - No grease	Replace drive unit Renovate or change the drive unit immediately Switch of power supply Replace drive unit
Sealing	- Wear sealing - Seal are not flushed - Seal surfaces stick together	Replace sealing Replace sealing and ensure that the seal never run dry Separate surfaces carefully and clean them - ensure that seals are sufficient cleaned before still stand
Other	- Deviation from normal operation - Circuit overload	Operation circumstances must be equal to those it was designed for ¹⁾ Operation circumstances must be equal to those it was designed for ¹⁾
Leakage		
Gear	- Oil leakage	Renovate or change the gear immediately
Sealing	- CIP fluid or other	Replace sealing
Continuously breakdown		
Drive unit	- Defect - Too high frequency	Replace motor Regulate frequency down
Other	- Deviation from normal operation	Operation circumstances must be equal to those it was designed for ¹⁾
Performance		
Drive unit Agitator Other	- Wrong frequency - Reverse direction - Deviation from normal operation	Check frequency connection Inspect the Agitator carefully Operation circumstances must be equal to those it was designed for ¹⁾

¹⁾ See chapter 2.3 Intended use.

4 Operation

Study the instructions carefully and pay special attention to warnings! **Always** check the Agitator before operation (see chapter 3.3 Pre-use check).

Alfa Laval recommend a soft starter or a frequency converter for the Agitator to reduce the load on tank and Agitator. For operation instructions from suppliers (see chapter 8 Appendix).

4.3 Cleaning - recommendations



Ensure the drain in flange is not clogged up, by cleaning drain regularly.



Ensure that all surfaces in contact with product are totally clean in order not to contaminate the product.

Pay special attention to:

- Impeller device surfaces
- Surfaces between impeller devices and shaft
- Surfaces around sealing
- Surfaces around weldings

CAUTION

Mechanical seals are designed for cleaning in place (CIP) and sterilising in place (SIP).

CIP = Cleaning In Place. SIP = Sterilising In Place.



Always rinse well with clean water after cleaning.

4.4 Temperature limits

The highest allowable ambient temperature is 40°C.

For applications without bearing frame (not ATEX):

The highest allowable continuous temperature of the SHAFT that goes into the gear motor is 105°C. Shorter periods with higher application temperatures, eg. 10-20 minutes during a sterilization phase or the like, can be allowed and accepted without changing the oil service interval and without reducing the lifetime of the gear motor. If longer periods with exceeded application temperatures are required, the actual temperature of the oil in the gear motor must be measured. The highest allowable oil temperature is 140°C and the oil service interval, which at 70°C is about 40.000 hours, will be reduced by 50% for each 15K the oil temperature is increased above the 70°C.

For applications with bearing frame (not ATEX):

The highest allowable continuous temperature of the SHAFT that goes into the bearing frame is 105°C. Shorter periods with higher application temperatures, eg. 10-20 minutes during a sterilization phase or the like, can be allowed and accepted without changing the service interval and without reducing the lifetime of the bearings. If longer periods with exceeded application temperatures are required, the actual temperature of the bearings must be measured. The highest allowable bearing temperature, without changing the service interval, is 120°C.

Study the instructions carefully and pay special attention to warnings! **Always** check the Agitator before operation (see chapter 3.3 Pre-use check).

Alfa Laval recommend a soft starter or a frequency converter for the Agitator to reduce the load on tank and Agitator. For operation instructions from suppliers (see chapter 8 Appendix).

4.5 Pressure limits

The ALS and ALB agitator can be equipped with different shaft seal types with different operating properties. The shaft seal is selected according to the application. In below table you will find the maximum allowable tank pressure during operation for the different seal types.

Seal type	Tank pressure [barg]		Designation
	Min.	Max.	
-S1-	-0.5	6.0	Single mechanical shaft seal, High pressure and high speed
-S2-	-0.5	6.0	Single mechanical shaft seal, High pressure and high speed
-S3-	-0.5	6.0	Single mechanical shaft seal, High pressure and high speed
-D-	-1.0	4.5*	Double mechanical shaft seal w. flush, Medium pressure and high speed
-DC-	-1.0	6.0	Double mechanical shaft seal w. flush, High pressure and high speed

*If the seal faces are submerged, the maximum tank pressure can be increased to 6.0bar(g).

NOTE

Above pressures are not taking limitations on flange connections according to local pressure regulations into consideration. Be aware that the operating pressure limits for the shaft seal can be lower than the tank design pressure.

5 Maintenance

For maintenance instructions from suppliers, see chapter 8 Appendix. **Always** ensure that mounting is according to chapter 6 Technical data. Ensure totally clean surfaces during mounting - also remove remaining loctite residue on threads. **Always** refer to tightening torques in chapter 6 Technical data.

5.1 General maintenance



Maintenance of the Agitator should only be performed by authorized personnel. For maintenance instructions from suppliers, see chapter 8 Appendix. Ensure totally clean surfaces during maintenance.



If possible, **always** dismantle the Agitator from tank before dismantling it. For lifting instruction, please refer to chapter 3 Installation.



Always read the technical data thoroughly (see chapter 6 Technical data).
Always ensure that the mounting is according to Agitator described in chapter 2.3 Intended use and chapter 6 Technical data.
Always refer to tightening torques in chapter 6 Technical data.
Always disconnect the power supply when servicing the Agitator.
Always use proper tools.
Always replace sealing elements before reassembling.

WARNING

Follow the dismantling and assembly instructions to the letter.
 After maintenance, chapter 3.3 Pre-use check must be read thoroughly before operation.

NOTE

All scrap must be stored/disposed of in accordance with current rules/directives.
 Use original Alfa Laval spare parts.

PREVENTIVE MAINTENANCE

To ensure that your Alfa Laval machine operates efficiently, it is essential to follow a simple preventive maintenance programme, which will keep your machine in good working conditions. Good maintenance requires careful attention at regular intervals!

The following recommended preventive maintenance procedures are based on the average operating conditions of most Alfa Laval machines. However, you will appreciate that a machine, which is subject to rough and dirty conditions, will need more frequent attention than one working in ideal conditions. We trust that you will adjust your maintenance programme to meet the demands of your normal operating conditions.

	Replace every:				
	500 hour or yearly	1000 hour or yearly	3000 hour or yearly	6000 hour or every 3rd year	10000 hour or every 3rd year
Sealing					
Mechanical seal					
-NOT flushed: S1, S2, S3				X	
-Flushed: DC, D					X
Bearing frame					
Spider type coupling (if any)					X
Static seals					X
Radial seals			X		
Bearings, rpm < 700					X
Bearings, rpm > 700				X	

For maintenance instructions from suppliers, see chapter 8 Appendix. **Always** ensure that mounting is according to chapter 6 Technical data. Ensure totally clean surfaces during mounting - also remove remaining loctite residue on threads. **Always** refer to tightening torques in chapter 6 Technical data.

5.2 Replacement of drive unit (with bearing frame)

Step 1

Remove shroud, if any.

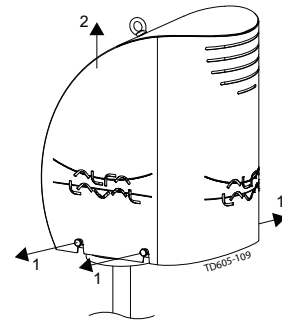

Step 2

Loosen cap nuts.

CAUTION

If dismantling motor from gear:
Follow supplier instructions.
Ensure that the gear oil is contained.
A cog wheel may be mounted onto the motor shaft.

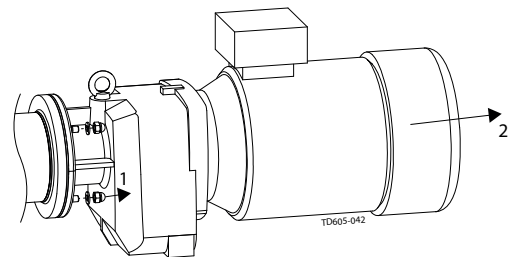

Step 3

Release the gear motor from the Agitator.

CAUTION

There is a spider type coupling mounted onto the gear motor shaft.

Step 4

Lift up the drive unit and pull it away.

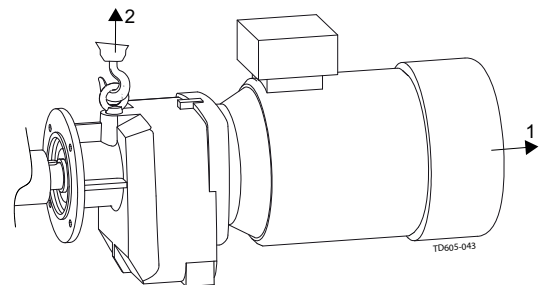

Step 5

1. Loosen coupling screws.
2. Pull the coupling of the gear motor shaft.

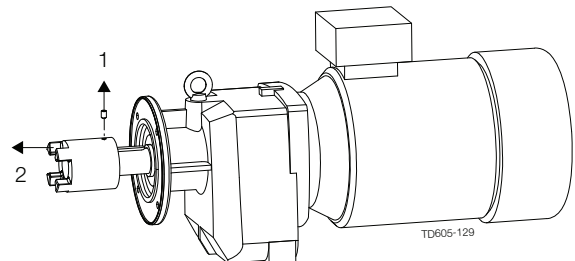

5 Maintenance

For maintenance instructions from suppliers, see chapter 8 Appendix. **Always** ensure that mounting is according to chapter 6 Technical data. Ensure totally clean surfaces during mounting - also remove remaining loctite residue on threads. **Always** refer to tightening torques in chapter 6 Technical data.

Step 6

Replace drive unit.
Mount coupling.

NOTE

Coupling part can be heated to 80-120°C for easier mounting onto gear motor shaft.

CAUTION

Ensure that the axial position of the coupling is according to illustration. The value XX is to be found in chapter 6.8 Spider coupling.

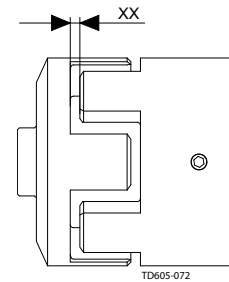

Step 7

Replace spider if necessary.
Use Loctite® 243 before fastening screws.
Always refer to tightening torques in chapter 6 Technical data when tightening bolts.

Step 8

Mount drive unit reverse as dismantling.

For maintenance instructions from suppliers, see chapter 8 Appendix. **Always** ensure that mounting is according to chapter 6 Technical data. Ensure totally clean surfaces during mounting - also remove remaining loctite residue on threads. **Always** refer to tightening torques in chapter 6 Technical data.

5.3 Replacement of drive unit (without bearing frame)

Step 1

Remove shroud, if any.

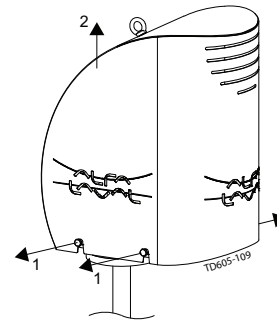

Step 2

1. Dismantle Agitator from welding flange.
2. Lift up Agitator.

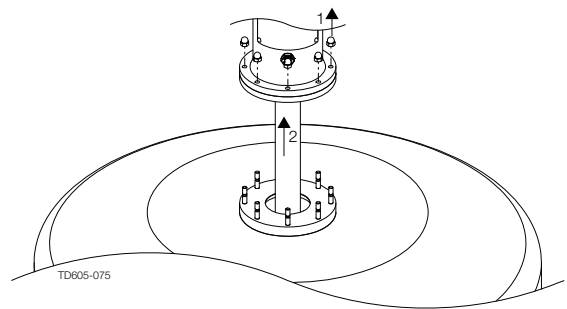

Step 3

Before dismantling drive unit, please see instructions in 5.10 Replacement of shaft seal, type D to 5.14 Replacement of shaft seal, type S3, depending on seal type.

Step 4

Loosen cap nuts.

CAUTION

If dismantling motor from gear:
Follow supplier instructions.
Ensure that the gear oil is contained.
A cog wheel may be mounted onto the motor shaft.

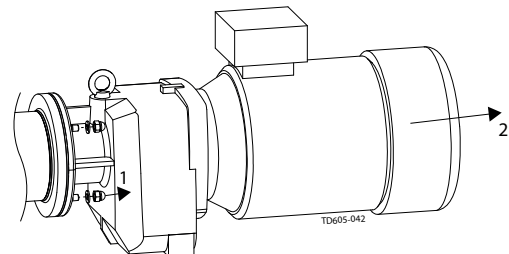

5 Maintenance

For maintenance instructions from suppliers, see chapter 8 Appendix. **Always** ensure that mounting is according to chapter 6 Technical data. Ensure totally clean surfaces during mounting - also remove remaining loctite residue on threads. **Always** refer to tightening torques in chapter 6 Technical data.

Step 5

Release the gear motor from the Agitator. Refer to supplier instructions.

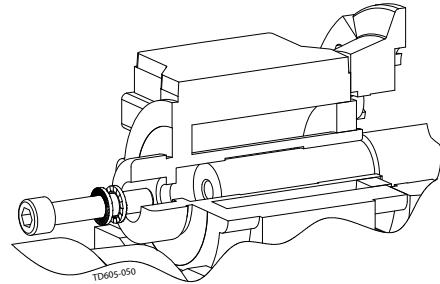

CAUTION

There is a Nord-lock® washer mounted on the gear fastening the shaft. The washer consists of two parts attached to each other with some silicone as shown on the picture. It is important that the two parts are positioned as shown.

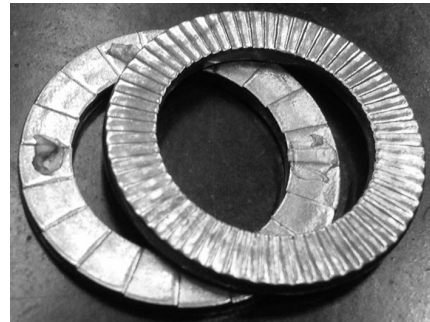

Step 6

Lift up the drive unit and pull it away.

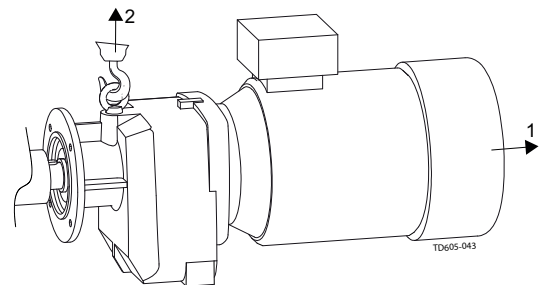

Step 7

Replacement drive unit.

Step 8

Use Loctite® 243 before fastening screws.

Always refer to tightening torques in chapter 6 Technical data.

Step 9

Mount drive unit reverse as dismantling.

For maintenance instructions from suppliers, see chapter 8 Appendix. **Always** ensure that mounting is according to chapter 6 Technical data. Ensure totally clean surfaces during mounting - also remove remaining loctite residue on threads. **Always** refer to tightening torques in chapter 6 Technical data.

5.4 Replacement of drive unit (Motor and shaft unit)

Step 1

Remove shroud, if any.

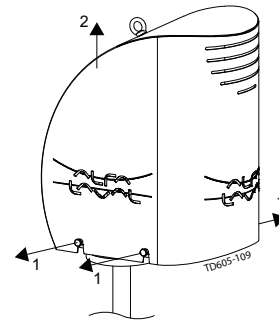

Step 2

Loosen cap nuts.

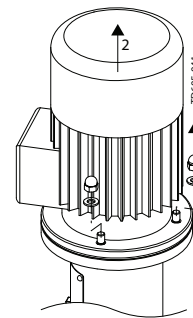

Step 3

Release the motor from the Agitator.

CAUTION

Motor and shaft are one complete unit.

Step 4

Lift up the drive unit and pull it away.

Step 5

Replace drive unit.

Step 6

Use Loctite® 243 before fastening screws.

Always refer to tightening torques in chapter 6 Technical data.

Step 7

Mount drive unit reverse as dismantling.

5 Maintenance

For maintenance instructions from suppliers, see chapter 8 Appendix. **Always** ensure that mounting is according to chapter 6 Technical data. Ensure totally clean surfaces during mounting - also remove remaining loctite residue on threads. **Always** refer to tightening torques in chapter 6 Technical data.

5.5 Dismantling and mounting shaft (with bearing frame except BC160)

Step 1

1. Dismantle Agitator from welding flange.
2. Lift up Agitator.

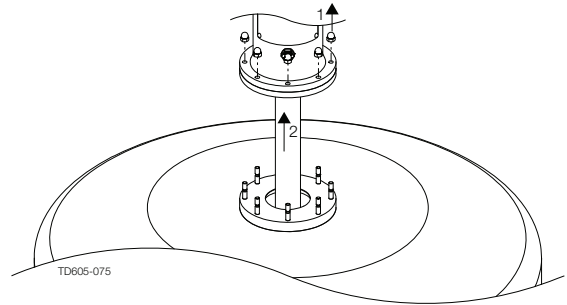

Step 2

1. Dismantle drive unit as described in chapter 5.2 Replacement of drive unit (with bearing frame).
2. Remove PreVent valve.

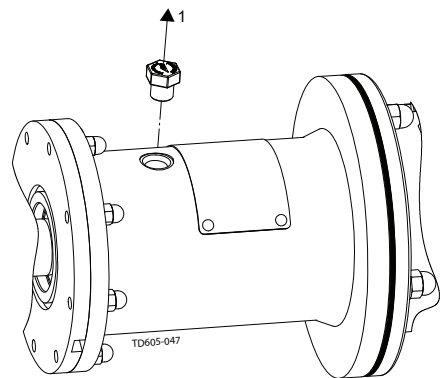

Step 3

Looking through the PreVent valve hole, rotate shaft until shaft locking hole aligns.

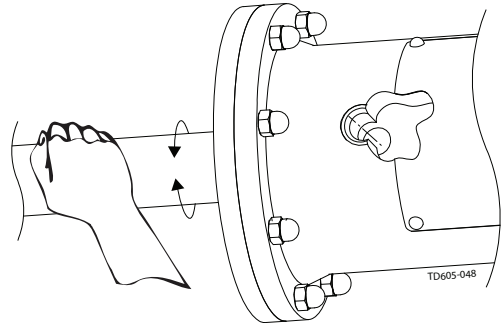

Step 4

1. Mount retainer bolt tool for shaft locking.
2. Remove centre bolt.

NOTE

Extra retainer bolt tool can be acquired if needed (see chapter 7.10 Tools) or Spare Part Manual.

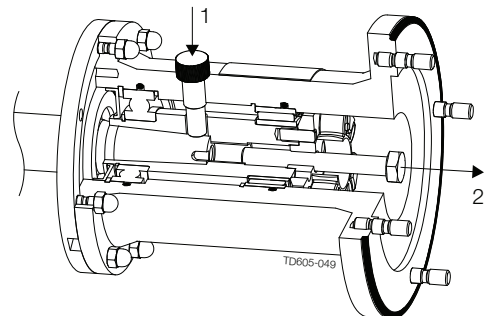

5 Maintenance

For maintenance instructions from suppliers, see chapter 8 Appendix. **Always** ensure that mounting is according to chapter 6 Technical data. Ensure totally clean surfaces during mounting - also remove remaining loctite residue on threads. **Always** refer to tightening torques in chapter 6 Technical data.

Step 5

Remove spider and coupling part.

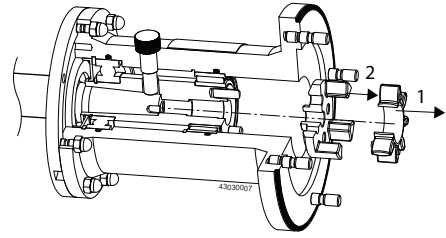

Step 6

Dismantle shaft by mounting extractor bolt tool. Keep turning extractor bolt until shaft is forced from the bearing frame.

NOTE

Extra extractor bolt tool can be acquired if needed (see chapter 7.10 Tools or Spare Part Manual).

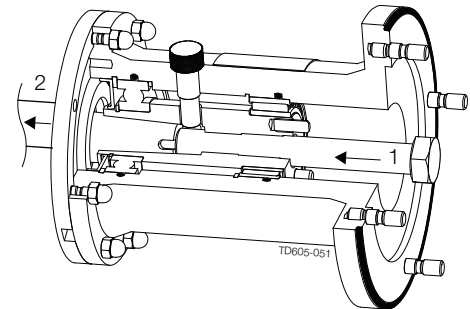

Step 7

Mount shaft reverse as dismantling

CAUTION

Ensure that oil trap ring, if any, is refitted correct during mounting.

5 Maintenance

For maintenance instructions from suppliers, see chapter 8 Appendix. **Always** ensure that mounting is according to chapter 6 Technical data. Ensure totally clean surfaces during mounting - also remove remaining loctite residue on threads. **Always** refer to tightening torques in chapter 6 Technical data.

5.6 Replacement of bearings, type B20, B25, B25/30, B35, B35/40, B45, B45/50, B55, B55/60

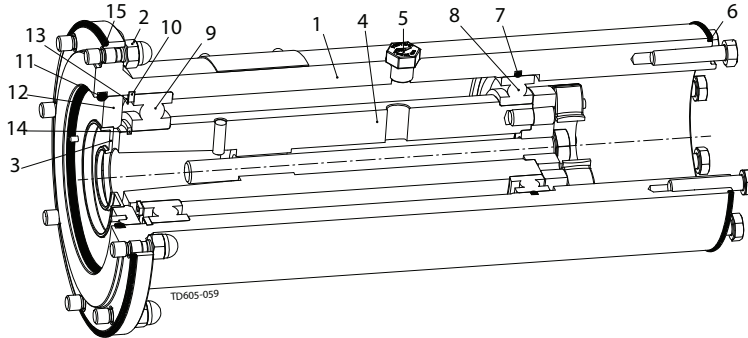

NOTE

Positions referred to in following instructions can be seen in the above illustration.

Step 1

1. Dismantle shaft as described in chapter 5.5 Dismantling and mounting shaft (with bearing frame except BC160).
2. Remove retainer bolt in Step 4 in chapter 5.5 Dismantling and mounting shaft (with bearing frame except BC160).

Step 2

1. Remove cap nuts (2).
2. Remove lantern or mounting flange if no lantern is used from bearing frame.

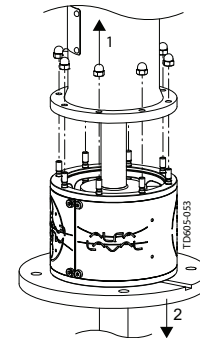

Step 3

1. Push cover (12) into bearing frame.
2. Remove o-ring (11).

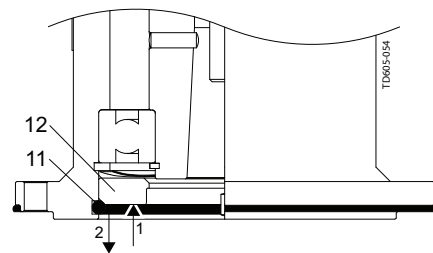

Step 4

Remove cover (12) including radial seal (3) and spring (13).

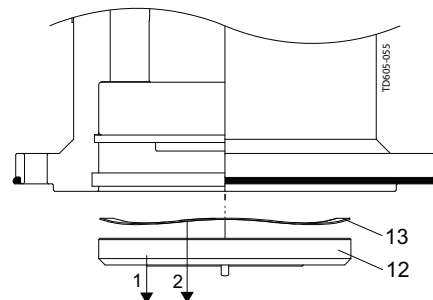

5 Maintenance

For maintenance instructions from suppliers, see chapter 8 Appendix. **Always** ensure that mounting is according to chapter 6 Technical data. Ensure totally clean surfaces during mounting - also remove remaining loctite residue on threads. **Always** refer to tightening torques in chapter 6 Technical data.

Step 5

Remove outer circlip (10) carefully. Use suited pliers.

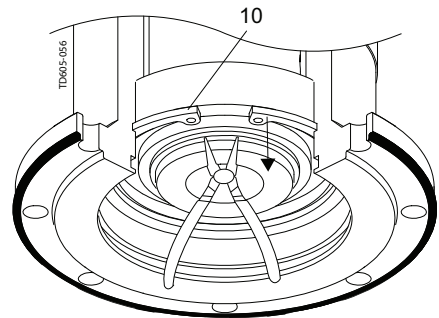

Step 6

1. Pull out drive shaft (4) including bearings (8, 9).
2. Remove o-ring (7)

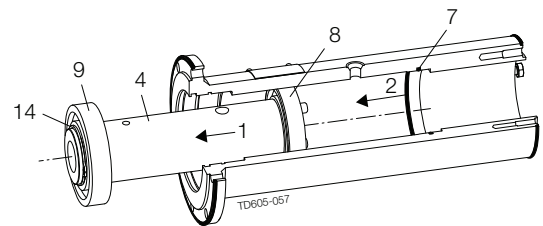

Step 7

1. Remove inner circlip (14) carefully. Use suited pliers.
2. Remove bearings (8, 9).

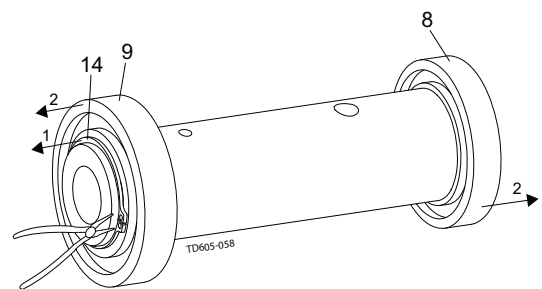

Step 8

1. Replace bearings (8, 9) and o-rings (6, 7, 11, 15).
2. Assembly of bearing frame is reverse as dismantling.

CAUTION

Only apply force to inner bearing rings when mounting bearings on drive shaft.

Only apply force to outer bearing rings when mounting drive shaft with bearings into bearing frame.

5 Maintenance

For maintenance instructions from suppliers, see chapter 8 Appendix. **Always** ensure that mounting is according to chapter 6 Technical data. Ensure totally clean surfaces during mounting - also remove remaining loctite residue on threads. **Always** refer to tightening torques in chapter 6 Technical data.

5.7 Replacement of bearings, type BC160DH

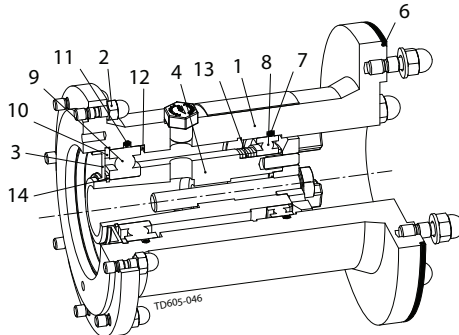

NOTE

Positions referred to in following instructions can be seen in the above illustration.

Step 1

Dismantle shaft as described in chapter 5.5 Dismantling and mounting shaft (with bearing frame except BC160).

Step 2

1. Remove cap nuts (2).
2. Remove lantern or mounting flange if no lantern is used from bearing frame.

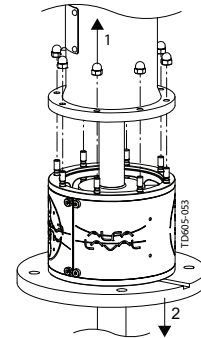

Step 3

Remove radial seal (3).

NOTE

Alfa Laval recommends replacing the radial seal.

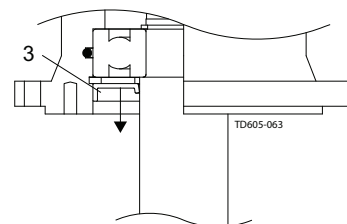

Step 4

Remove outer circlip (10) carefully. Use suited pliers.

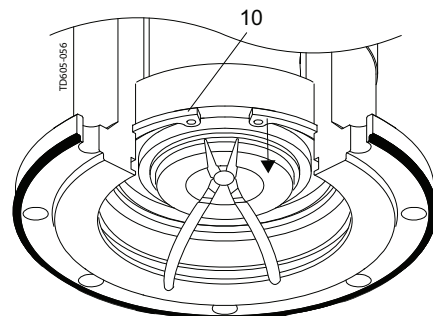

5 Maintenance

For maintenance instructions from suppliers, see chapter 8 Appendix. **Always** ensure that mounting is according to chapter 6 Technical data. Ensure totally clean surfaces during mounting - also remove remaining loctite residue on threads. **Always** refer to tightening torques in chapter 6 Technical data.

Step 5

1. Pull out drive shaft (4) including bearings (8, 9).
2. Remove O-rings, (7), (11).

Step 6

1. Remove spring ring (13).
2. Remove inner circlip (14) carefully. Use suited pliers.
3. Remove bearings (8, 9).

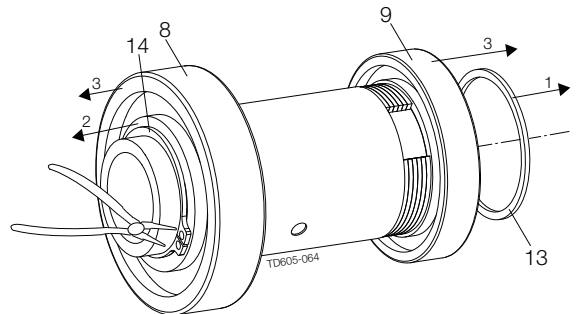

Step 7

1. Replace bearings (8, 9) and o-rings (6, 7, 11).
2. Assembly of bearing frame is reverse as dismantling.

CAUTION

Only apply force to inner bearing rings when mounting bearings on drive shaft.
Only apply force to outer bearing rings when mounting drive shaft with bearings into bearing frame.

5 Maintenance

For maintenance instructions from suppliers, see chapter 8 Appendix. **Always** ensure that mounting is according to chapter 6 Technical data. Ensure totally clean surfaces during mounting - also remove remaining loctite residue on threads. **Always** refer to tightening torques in chapter 6 Technical data.

5.8 Replacement of bearing, type BC160D

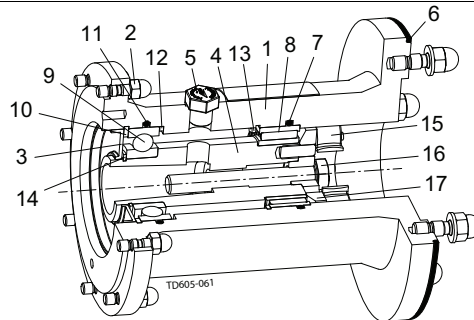

NOTE

Positions referred to in following instructions can be seen in the above illustration.

Step 1

Dismantle shaft as described in chapter 5.5 Dismantling and mounting shaft (with bearing frame except BC160).

Step 2

1. Remove cap nuts (2).
2. Remove lantern or mounting flange if no lantern is used from bearing frame

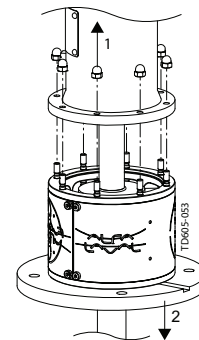

Step 3

Remove radial seal (3).

NOTE

Alfa Laval recommends replacing the radial seal.

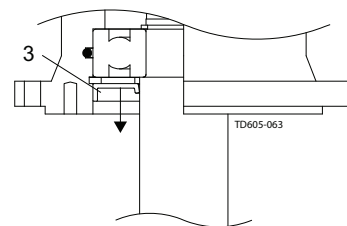

Step 4

Remove outer circlip (10) carefully. Use suited pliers.

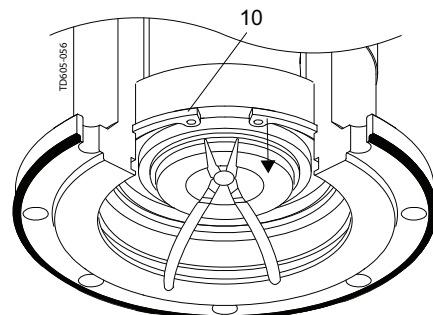

5 Maintenance

For maintenance instructions from suppliers, see chapter 8 Appendix. **Always** ensure that mounting is according to chapter 6 Technical data. Ensure totally clean surfaces during mounting - also remove remaining loctite residue on threads. **Always** refer to tightening torques in chapter 6 Technical data.

Step 5

1. Pull out drive shaft (4) including bearings (pos 8a, 9).
2. Pull out circlip (12) or let it stay in bearing frame.

NOTE

Outer bearing ring (8b) should stay in bearing frame

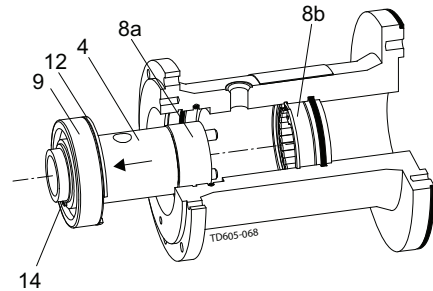

Step 6

1. Remove upper circlip (13) carefully. Use suited pliers.
2. Push out, using applicable tool, the outer bearing ring (8b).
3. Remove o-rings (7, 11).

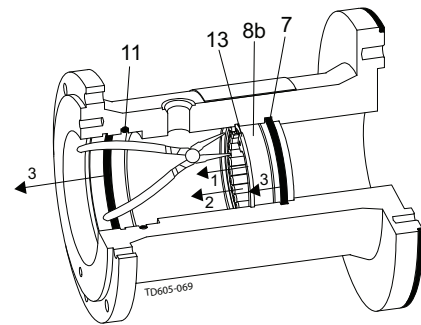

Step 7

1. Remove inner circlip (14) carefully. Use suited pliers.
2. Remove bearings (8a, 9)

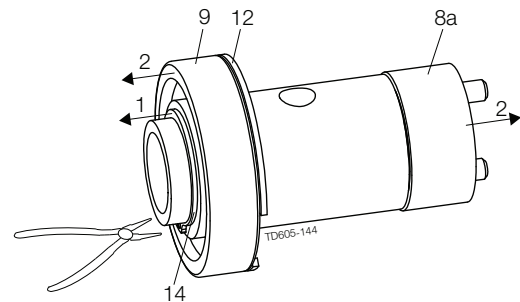

Step 8

1. Replace bearings (8a, 8b), (9) and o-rings (6, 7, 11).
2. Assembly of bearing frame is reverse as dismantling.

CAUTION

Only apply force to inner bearing rings when mounting bearings on drive shaft.

Only apply force to outer bearing rings when mounting drive shaft with bearings into bearing frame

5 Maintenance

For maintenance instructions from suppliers, see chapter 8 Appendix. **Always** ensure that mounting is according to chapter 6 Technical data. Ensure totally clean surfaces during mounting - also remove remaining loctite residue on threads. **Always** refer to tightening torques in chapter 6 Technical data.

5.9 Replacement of bearings type BC160

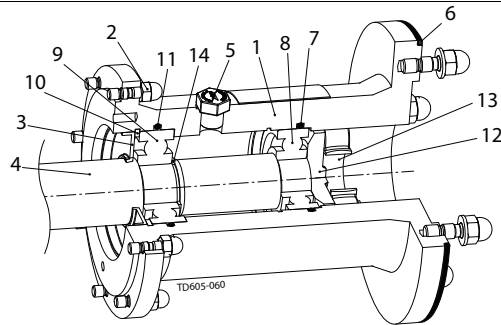

NOTE

Positions referred to in following instructions can be seen in the above illustration.

Step 1

Dismantle drive unit as described in chapter 5.2 Replacement of drive unit (with bearing frame).

Step 2

1. Remove cap nuts (2).
2. Remove lantern or mounting flange if no lantern is used from bearing frame.

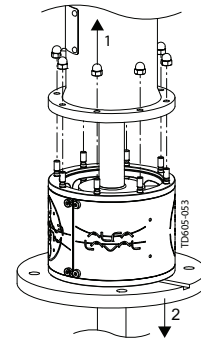

Step 3

Remove radial seal (3).

NOTE

Alfa Laval recommends replacing the radial seal.

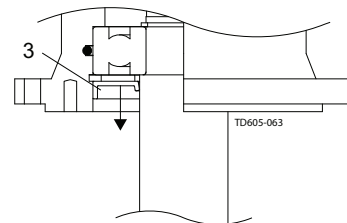

Step 4

Remove outer circlip (10) carefully. Use suited pliers.

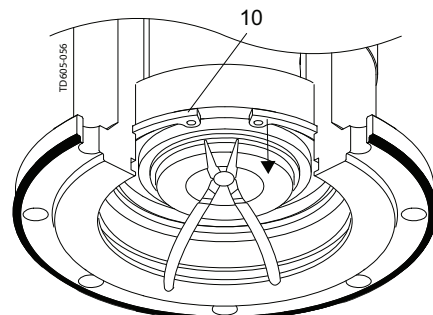

5 Maintenance

For maintenance instructions from suppliers, see chapter 8 Appendix. **Always** ensure that mounting is according to chapter 6 Technical data. Ensure totally clean surfaces during mounting - also remove remaining loctite residue on threads. **Always** refer to tightening torques in chapter 6 Technical data.

Step 5

1. Pull out shaft (4) including bearings (pos 8, 9).
2. Remove o-rings (7, 11).

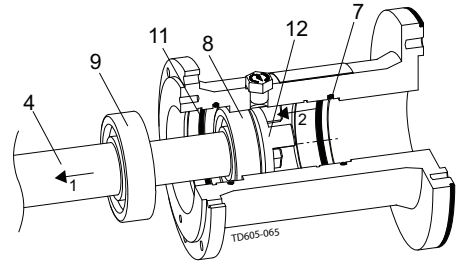

Step 6

1. Secure shaft (4), without causing surface damage to it.
2. Remove coupling (12) by turning it the opposite direction indicated by arrow on nameplate

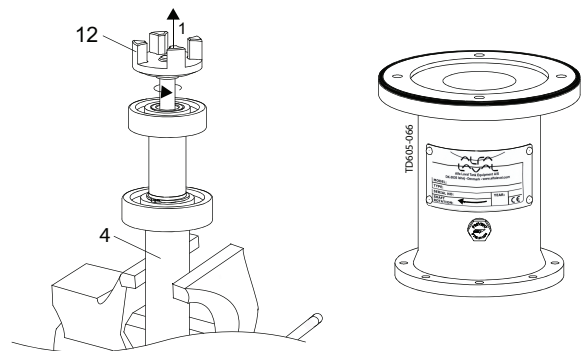

Step 7

1. Remove bearing (8).
2. Remove inner circlip (14) carefully. Use suited pliers.
3. Remove bearing (9).

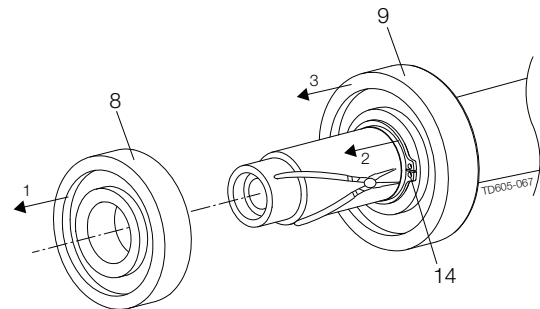

Step 8

1. Replace bearings (8, 9) and o-rings (6, 7, 11).
2. Assembly of bearing frame is reverse as dismantling.

CAUTION

Only apply force to inner bearing rings when mounting bearings on drive shaft.

5 Maintenance

For maintenance instructions from suppliers, see chapter 8 Appendix. **Always** ensure that mounting is according to chapter 6 Technical data. Ensure totally clean surfaces during mounting - also remove remaining loctite residue on threads. **Always** refer to tightening torques in chapter 6 Technical data.

5.10 Replacement of shaft seal, type D

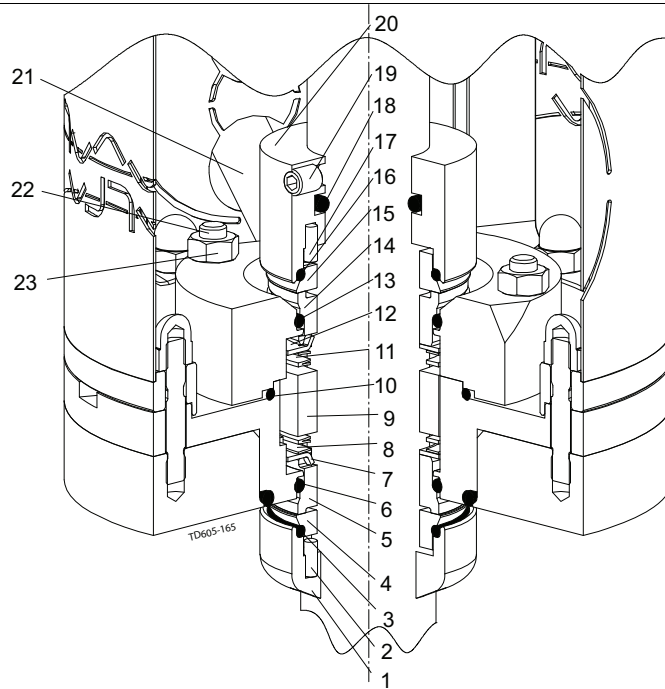

NOTE

To replace seals easier, use detergent.

Ensure subsequent to seal replacement, that all seal faces are totally clean, using alcohol.

Positions referred to in following instructions can be seen in the above illustration.

NOTE

If possible, **always** dismantle the Agitator from the tank before dismantling any parts.

Step 1

1. Dismantle Agitator from welding flange.
2. Lift up Agitator

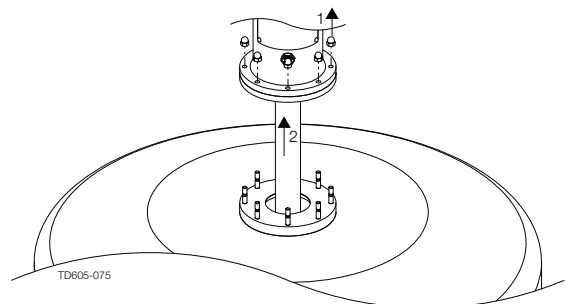

Step 2

1. Remove flush connections (21).
2. Remove guards from lantern.

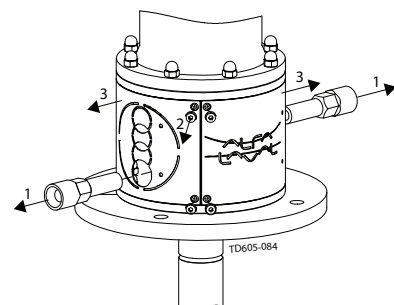

5 Maintenance

For maintenance instructions from suppliers, see chapter 8 Appendix. **Always** ensure that mounting is according to chapter 6 Technical data. Ensure totally clean surfaces during mounting - also remove remaining loctite residue on threads. **Always** refer to tightening torques in chapter 6 Technical data.

Step 3

Move oil trap ring and o-rings, if any, along the shaft.

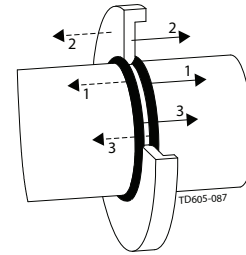

Step 4

1. Loosen pointed screw (19).
2. Move the rotary seal housing (20) and rotary seal part (15, 16, 18) carefully along the shaft.

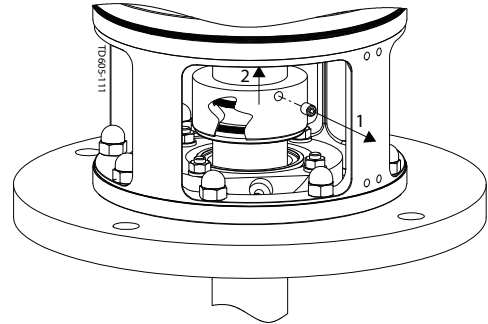

Step 5

Dismantle drive unit as described in chapter 5.2 Replacement of drive unit (with bearing frame).

Step 6

1. Dismantle shaft as described in section 5.2 Replacement of drive unit (with bearing frame) or 5.5 Dismantling and mounting shaft (with bearing frame except BC160), depending on actual Agitator type.
2. Remove shaft and rotary seal parts (3, 4) carefully, avoiding contact.

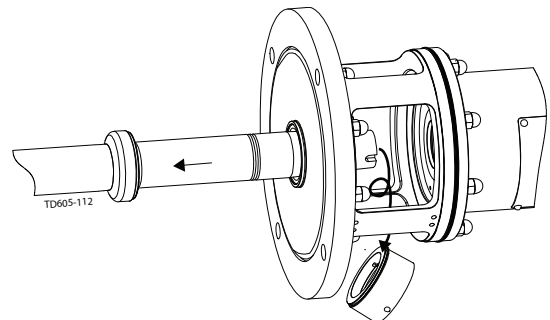

CAUTION

Ensure rotary seal housing and rotary seal part do **NOT** fall when shaft is removed.

5 Maintenance

For maintenance instructions from suppliers, see chapter 8 Appendix. **Always** ensure that mounting is according to chapter 6 Technical data. Ensure totally clean surfaces during mounting - also remove remaining loctite residue on threads. **Always** refer to tightening torques in chapter 6 Technical data.

Step 7

1. Remove nuts (23) and washers, securing stationary seal housing.
2. Remove stationary seal housing.

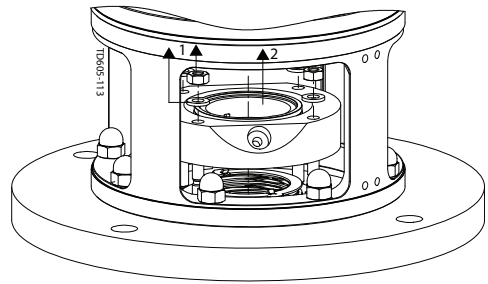

Step 8

1. Replace all seal parts.
2. Assemble Agitator reverse as dismantling.

CAUTION

Ensure clearance between rotary and stationary seal housing is 2,75 mm.

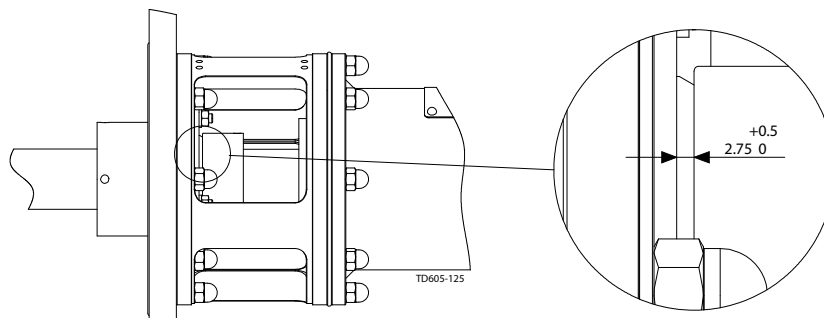

For maintenance instructions from suppliers, see chapter 8 Appendix. **Always** ensure that mounting is according to chapter 6 Technical data. Ensure totally clean surfaces during mounting - also remove remaining loctite residue on threads. **Always** refer to tightening torques in chapter 6 Technical data.

5.11 Replacement of shaft seal, type DC

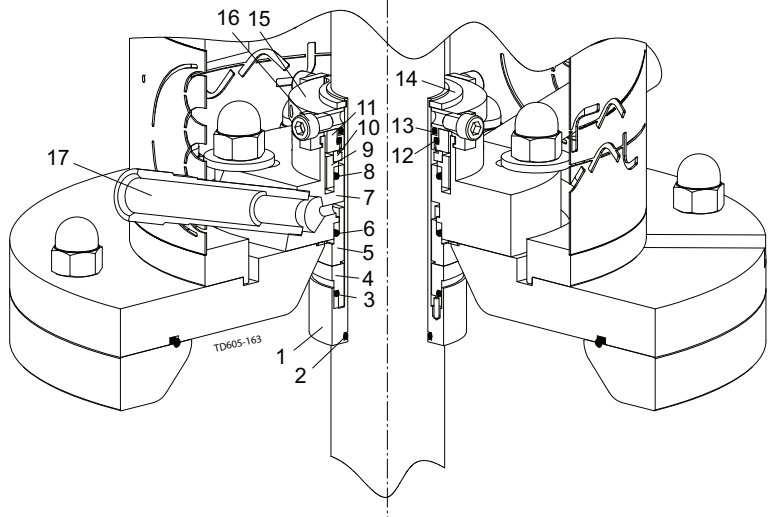

NOTE

To replace seals easier, use detergent. Ensure subsequent to seal replacement, that all seal faces are totally clean, using alcohol. Positions referred to in following instructions can be seen in the above illustration.

Step 1

- 1. Dismantle Agitator from welding flange.
- 2. Lift up Agitator.

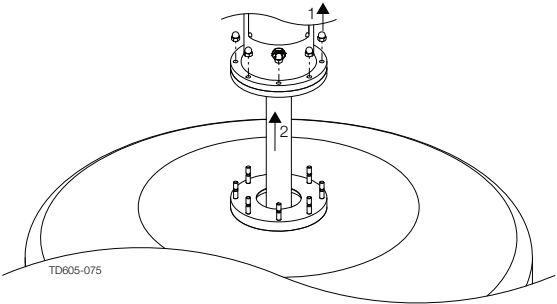

Step 2

- 1. Remove flush connections (17).
- 2. Remove guards from lantern.

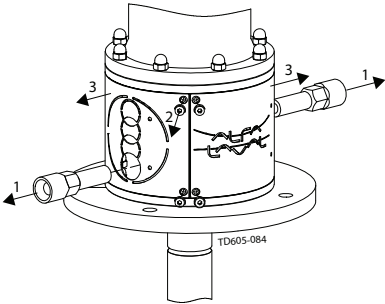

5 Maintenance

For maintenance instructions from suppliers, see chapter 8 Appendix. **Always** ensure that mounting is according to chapter 6 Technical data. Ensure totally clean surfaces during mounting - also remove remaining loctite residue on threads. **Always** refer to tightening torques in chapter 6 Technical data.

Step 3

1. Rotate distance pieces as shown in Step 9.
2. Loosen pointed screws (the pointed screws are not the screws that fasten the distance pieces).
3. Loosen cap nut, securing the seal
4. Ensure the seal can move along the shaft (up to 10 mm).

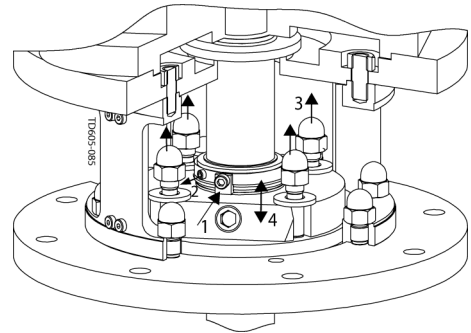

Step 4

Move oil trap ring and o-rings, if any, along the shaft.

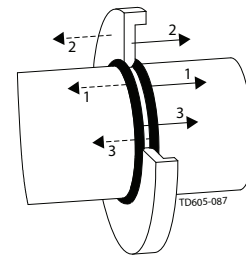

Step 5

1. Remove cap nuts, securing mounting flange.

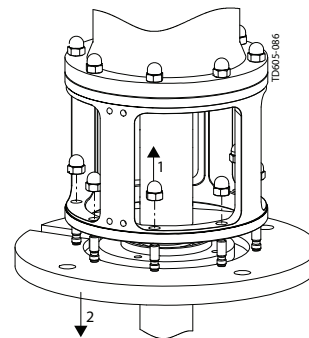

Step 6

Dismantle shaft, as described in chapter 5.2 Replacement of drive unit (with bearing frame) or 5.5 Dismantling and mounting shaft (with bearing frame except BC160) depending on Agitator type and carefully remove lantern.

Step 7

Lift lantern and drive unit flange.

Step 8

Remove DC seal.

For maintenance instructions from suppliers, see chapter 8 Appendix. **Always** ensure that mounting is according to chapter 6 Technical data. Ensure totally clean surfaces during mounting - also remove remaining loctite residue on threads. **Always** refer to tightening torques in chapter 6 Technical data.

Step 9

1. Replace sealing.
2. Assemble Agitator reverse as dismantling.

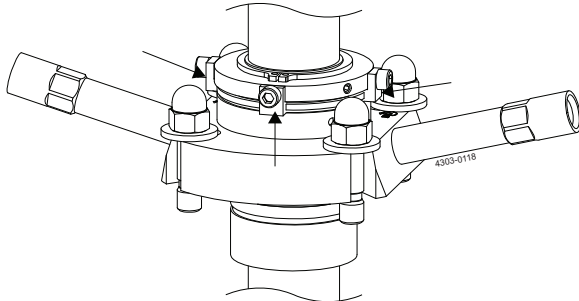

During mounting / dismantling

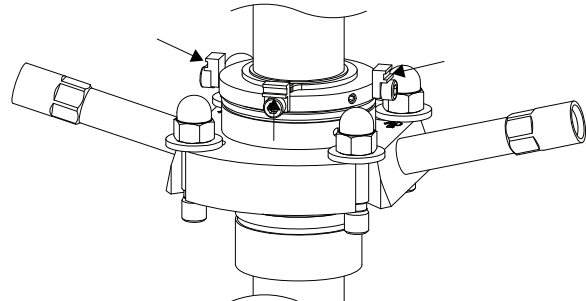

Before start

NOTE

Ensure distance pieces are oriented correctly during mounting or dismantling.

5 Maintenance

For maintenance instructions from suppliers, see chapter 8 Appendix. **Always** ensure that mounting is according to chapter 6 Technical data. Ensure totally clean surfaces during mounting - also remove remaining loctite residue on threads. **Always** refer to tightening torques in chapter 6 Technical data.

5.12 Replacement of shaft seal, type S1

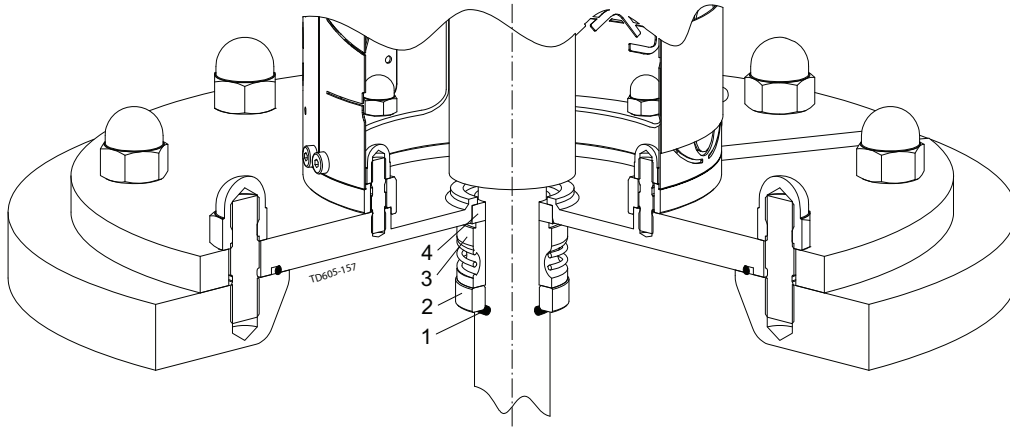

NOTE

To replace seals easier, use detergent.

Ensure subsequent to seal replacement, that all seal faces are totally clean, using alcohol.

If possible, always dismantle the Agitator from the tank before dismantling any parts.

Step 1

1. Dismantle Agitator from welding flange.
2. Lift up Agitator.

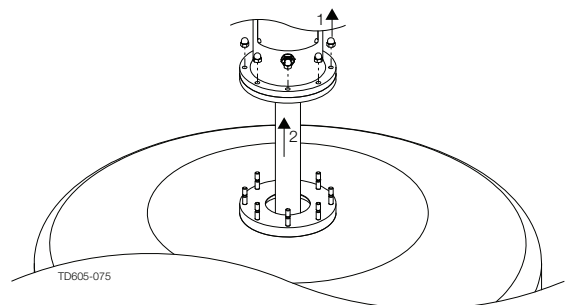

Step 2

1. Move o-ring (1) along the shaft.
2. Move counter ring (2) along the shaft.
3. Move rotary seal ring (3) along the shaft.

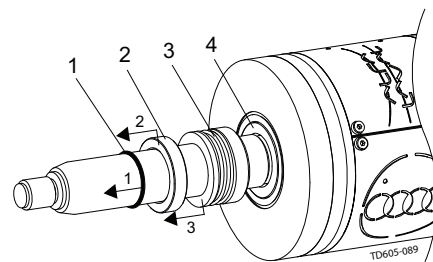

Step 3

Remove guards from lantern if lantern is used.

5 Maintenance

For maintenance instructions from suppliers, see chapter 8 Appendix. **Always** ensure that mounting is according to chapter 6 Technical data. Ensure totally clean surfaces during mounting - also remove remaining loctite residue on threads. **Always** refer to tightening torques in chapter 6 Technical data.

Step 4

1. Remove cap nuts (if still here).
2. Move the mounting flange, including stationary seal ring (4), carefully along the shaft.

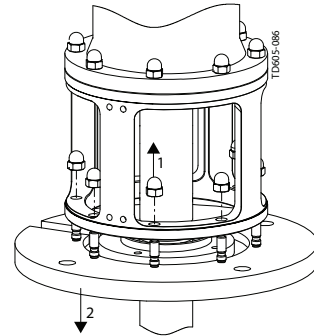

Step 5

Move oil trap ring and o-rings, if any, along the shaft.

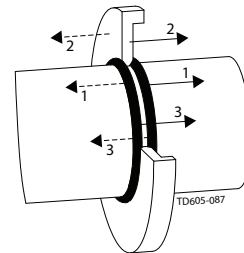

Step 6

If necessary, dismantle drive unit as described in chapter 5.2 Replacement of drive unit (with bearing frame).

Step 7

Push stationary seal ring (4) out of the mounting flange.

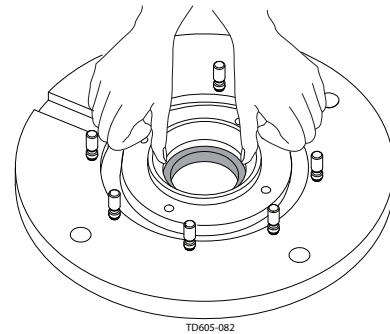

Step 8

Remove all seal parts from shaft.

Step 9

1. Replace all seal parts.
2. Assemble Agitator reverse as dismantling.

5 Maintenance

For maintenance instructions from suppliers, see chapter 8 Appendix. **Always** ensure that mounting is according to chapter 6 Technical data. Ensure totally clean surfaces during mounting - also remove remaining loctite residue on threads. **Always** refer to tightening torques in chapter 6 Technical data.

5.13 Replacement of shaft seal, type S2

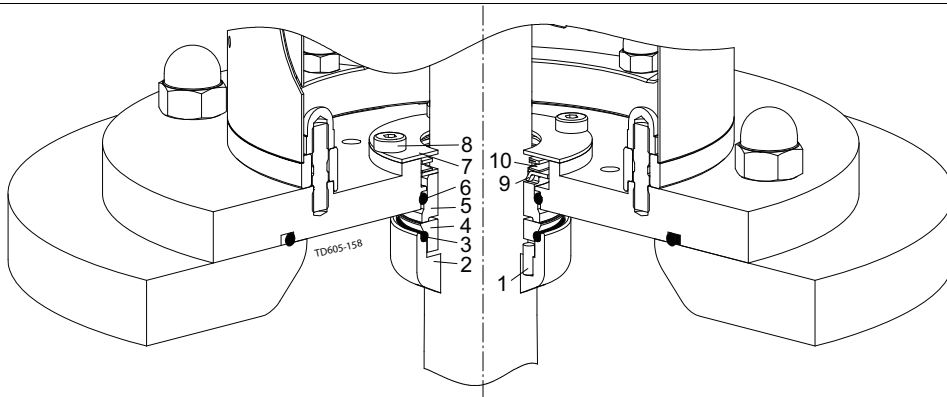

NOTE

To replace seals easier, use detergent.
Ensure subsequent to seal replacement, that all seal faces are totally clean, using alcohol.

NOTE

If possible, **always** dismantle the Agitator from the tank before dismantling any parts.

Step 1

1. Dismantle Agitator from welding flange.
2. Lift up Agitator

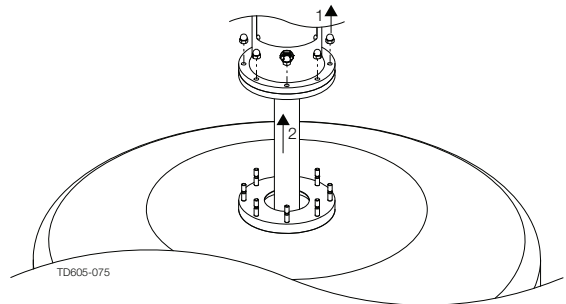

Step 2

Remove guards from lantern if lantern is used.

Step 3

Move oil trap ring and o-rings, if any, along the shaft.

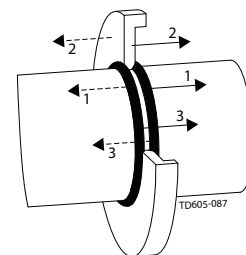

Step 4

Remove carefully the shaft without dismantling drive unit.

5 Maintenance

For maintenance instructions from suppliers, see chapter 8 Appendix. **Always** ensure that mounting is according to chapter 6 Technical data. Ensure totally clean surfaces during mounting - also remove remaining loctite residue on threads. **Always** refer to tightening torques in chapter 6 Technical data.

Step 5

Remove rotary seal part from shaft.

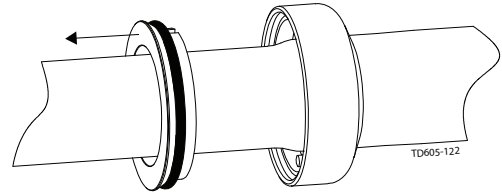

Step 6

Remove stationary seal part and o-ring from mounting flange.

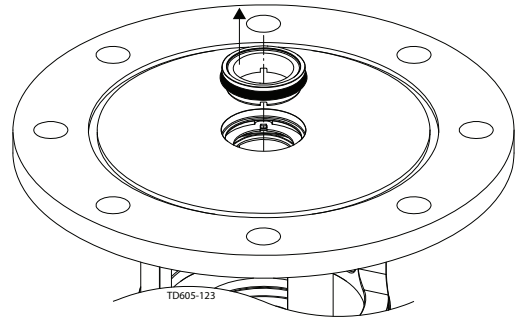

Step 7

1. Remove screws.
2. Remove retainer ring.
3. Remove spring and stationary drive ring.

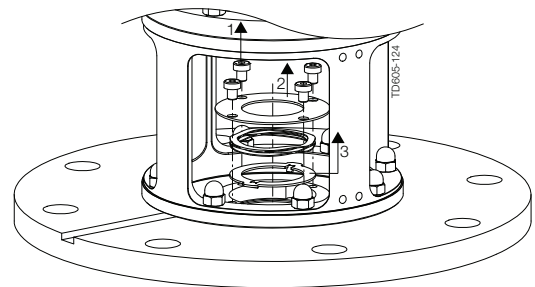

Step 8

1. Replace all seal parts.
2. Assemble Agitator reverse as dismantling.

5 Maintenance

For maintenance instructions from suppliers, see chapter 8 Appendix. **Always** ensure that mounting is according to chapter 6 Technical data. Ensure totally clean surfaces during mounting - also remove remaining loctite residue on threads. **Always** refer to tightening torques in chapter 6 Technical data.

5.14 Replacement of shaft seal, type S3

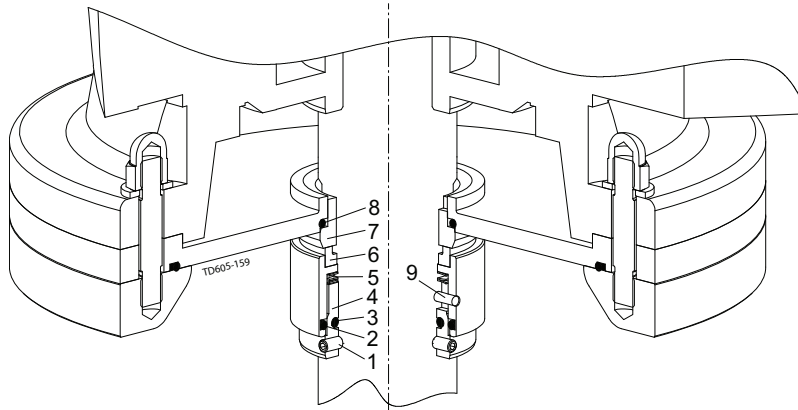

NOTE

To replace seals easier, use detergent.

Ensure subsequent to seal replacement, that all seal faces are totally clean, using alcohol.

If possible, **always** dismantle the Agitator from the tank before dismantling any parts.

The seal (see chapter 2.3 Intended use) is designed for dry running, so a whining noise during operation is quite normal.

Positions referred to in following instructions can be seen in the above illustration.

Step 1

1. Dismantle Agitator from welding flange.
2. Lift up Agitator

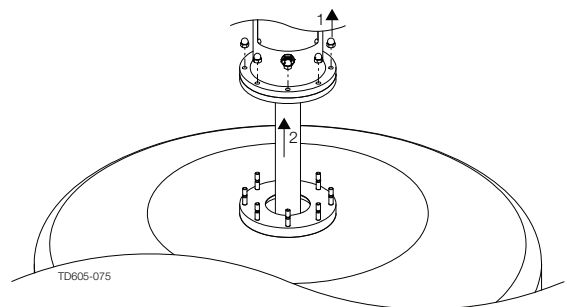

Step 2

1. Loosen pointed screws (1), securing rotary seal housing onto the shaft.
2. Move the seal housing, including rotary seal part, by pulling it carefully along the shaft, avoiding contact.

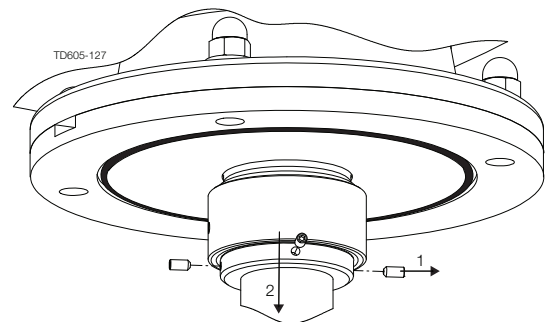

NOTE

Use mild detergent to reduce friction.

5 Maintenance

For maintenance instructions from suppliers, see chapter 8 Appendix. **Always** ensure that mounting is according to chapter 6 Technical data. Ensure totally clean surfaces during mounting - also remove remaining loctite residue on threads. **Always** refer to tightening torques in chapter 6 Technical data.

Step 3

1. Remove guards from lantern.
2. Remove cap nuts.
3. Move the mounting flange, including stationary seal ring, carefully along the shaft, avoiding contact.

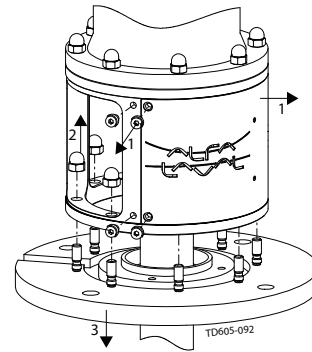

Step 4

Move oil trap ring and o-rings, if any, along the shaft.

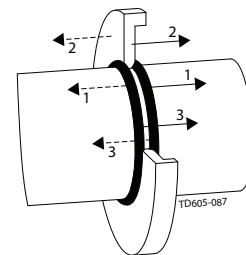

Step 5

1. Push stationary seal ring (7) out of the mounting flange.

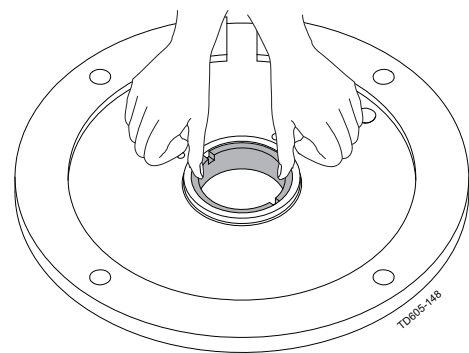

Step 6

Remove all seal parts from shaft.

Step 7

1. Replace all seal parts.
2. Assemble Agitator reverse as dismantling and position the rotating seal element according to measure x.

Shaft size:

Ø30, x=36

Ø35, x=36

Ø40, x=38

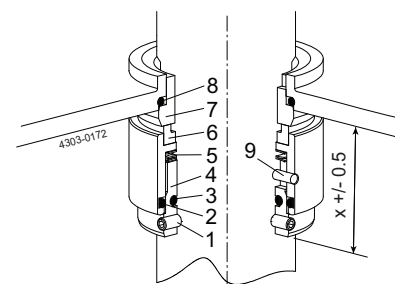

6 Technical data

All dimensions in mm unless otherwise stated.

6.1 Technical data

The Alfa Laval Agitator is available in various configurations and is configured to solve the specific application. Therefore specific information like weight, size, critical oscillation speed and duties can be found in the supplied Alfa Laval quotation agreement.

Important installation information about weight and mounting angle can be found on the supplied Agitator name plate as shown on the illustration.

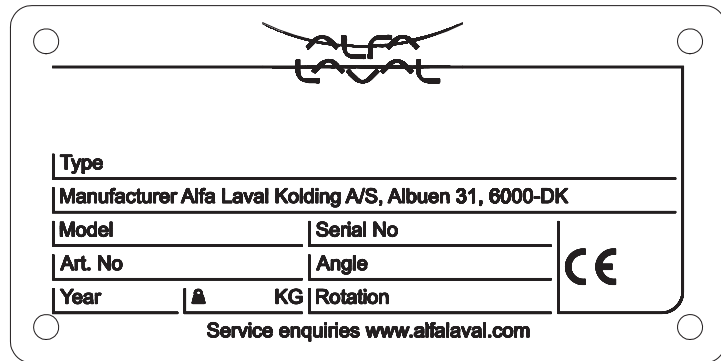

6.2 Mounting angle for side mounted Agitator type ALS

To ensure optimal agitation the side mounted Agitator must be installed in the mounting angle specified on the name plate, as described in the Alfa Laval quotation agreement and as shown on the illustration.

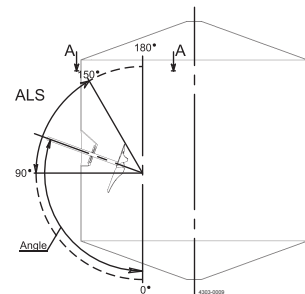

The side mounted Agitator must also be installed in either an offset distance (E) from the center of the tank or it must be installed an offset angle (E*) from the center of the tank as shown on illustration section A-A

The distance (E) can be calculated as follows:
 $E = C \times \tan(5-7^\circ)$, where C = tank radius

If the offset angle is chosen it must be as follows: $E^* = 5-7^\circ$

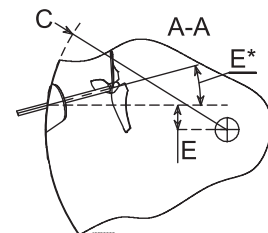

NOTE

In certain cases the offset angle E* is recommended to be larger - e.g. 10-12°.
 - it will be communicated via the Alfa Laval quotation agreement.

All dimensions in mm unless otherwise stated.

6.3 Mounting angle for bottom mounted Agitator type ALB

To ensure optimal agitation the bottom mounted Agitator must be installed in the mounting angle specified on the name plate, as described in the Alfa Laval quotation agreement and as shown on the illustration.

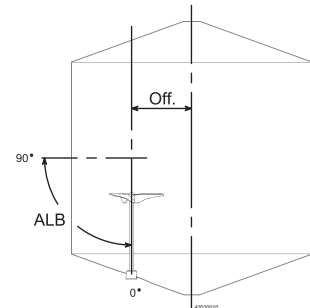

6 Technical data

All dimensions in mm unless otherwise stated.

6.4 Connecting flush – Seal type D

Flush connection:

In and out: Male 1/2"-14 BSP (ISO 7/1-Rp)
Flushing pressure max. 2.0 bar(g)

Flush media pressure recommendation to prevent flush media contamination by the product media:

(flush media pressure > tank operating pressure)
- Flushing pressure \geq (Tank operating pressure + 0.1 bar)

NOTE

Tank pressure cannot be higher than 1.9 bar(g) due to the maximum flushing pressure. If higher tank pressure is needed the next flush media pressure recommendation must be followed.

Flush media pressure recommendation to prevent product media contamination by the flush media:

(tank operating pressure > flush media pressure)
- Flushing pressure \leq (Tank operating pressure – 0.1 bar)
- (Tank operating pressure – Flushing pressure) \leq 2.5 bar

NOTE

If the tank pressure is more than 2.5 bar(g) greater than the flushing pressure, there will be a risk of dry running on the primary seal faces when the seal faces is not submerged. When the seal faces are submerged there is no limit on the pressure difference during operation.

Flush media flow recommendation:

- Flushing flow rate > 0.25 ltr/min
- Lower flushing flow rate is allowed as long as the temperature difference between in- and outlet is < 10°C

Flush media type recommendation:

- White oils
- Water
- Wet steam
- Alcohol

All dimensions in mm unless otherwise stated.

Flush media type recommendation:

- Always use appropriately in- and outlet temperatures given for current seal elastomers
- Inlet temperature to be 15°C below actual fluid boiling point (temperature and pressure dependent)
- Always use wet steam (H₂O) if steam is used as flushing fluid
- Inlet temperature ≤ 121°C

Sterile barrier at seal type D and DC:

- Use a sterile supply system with preferred sterilization temperature and water / wet steam as flush type and ensure that above recommendations are followed

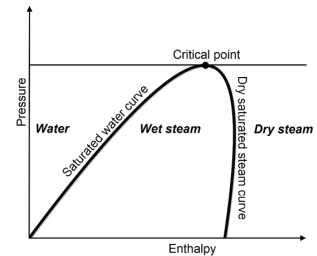

Ensure flush connections are not installed or oriented in such way that air pockets will appear. In some cases initial air pockets near the seal surfaces (e.g. at bottom mounted Agitators ALB) cannot be avoided. It has been tested and verified that an initial flow rate without air at 5 ltr/min lasting for 30 seconds while the Agitator is running ensures that all air in seal and flushing chamber will be flushed out.

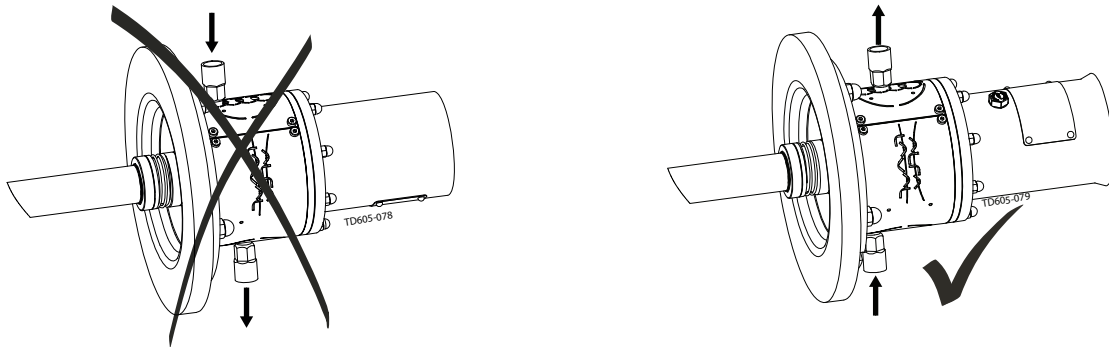

NOTE

Alfa Laval recommends installing a pressure relief valve to ensure pressure never exceed specifications.
 Alfa Laval recommends installing a non-return valve onto the inlet connection, to ensure that the seal never runs dry.
 If higher flushing pressure is desired, please contact Alfa Laval for advice.

6 Technical data

All dimensions in mm unless otherwise stated.

6.5 Connecting flush – Seal type DC

Flush connection:

In and out: Male 1/2"-14 BSP (ISO 7/1-Rp)
Flushing pressure max. 7.0 bar(g)

Flush media pressure recommendation to prevent flush media contamination by the product media:

(flush media pressure > tank operating pressure)
- Flushing pressure \geq (Tank operating pressure + 0.1 bar)

Flush media pressure recommendation to prevent product media contamination by the flush media:

(tank operating pressure > flush media pressure)
- Flushing pressure \leq (Tank operating pressure – 0.1 bar)
- (Tank operating pressure – Flushing pressure) \leq 2.5 bar

NOTE

If the tank pressure is more than 2.5 bar(g) greater than the flushing pressure, there will be a risk of dry running on the primary seal faces when the seal faces is not submerged. When the seal faces are submerged there is no limit on the pressure difference during operation.

Flush media flow recommendation:

- Flushing flow rate > 0.25 ltr/min
- Lower flushing flow rate is allowed as long as the temperature difference between in- and outlet is < 10°C

All dimensions in mm unless otherwise stated.

Flush media type recommendation:

- White oils
- Water
- Wet steam
- Alcohol

Flush media type recommendation:

- Always use appropriately in- and outlet temperatures given for current seal elastomers
- Inlet temperature to be 15°C below actual fluid boiling point (temperature and pressure dependent)
- Always use wet steam (H₂O) if steam is used as flushing fluid
- Inlet temperature ≤ 121°C

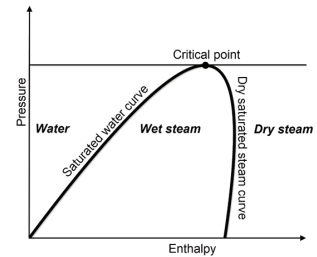

Sterile barrier at seal type D and DC:

- Use a sterile supply system with preferred sterilization temperature and water / wet steam as flush type and ensure that above recommendations are followed

Ensure that connection of outlet and inlet is correct, with regard to Agitator rotation direction!
Ensure that the distance pieces (1) on the seal are mounted as shown on illustration.

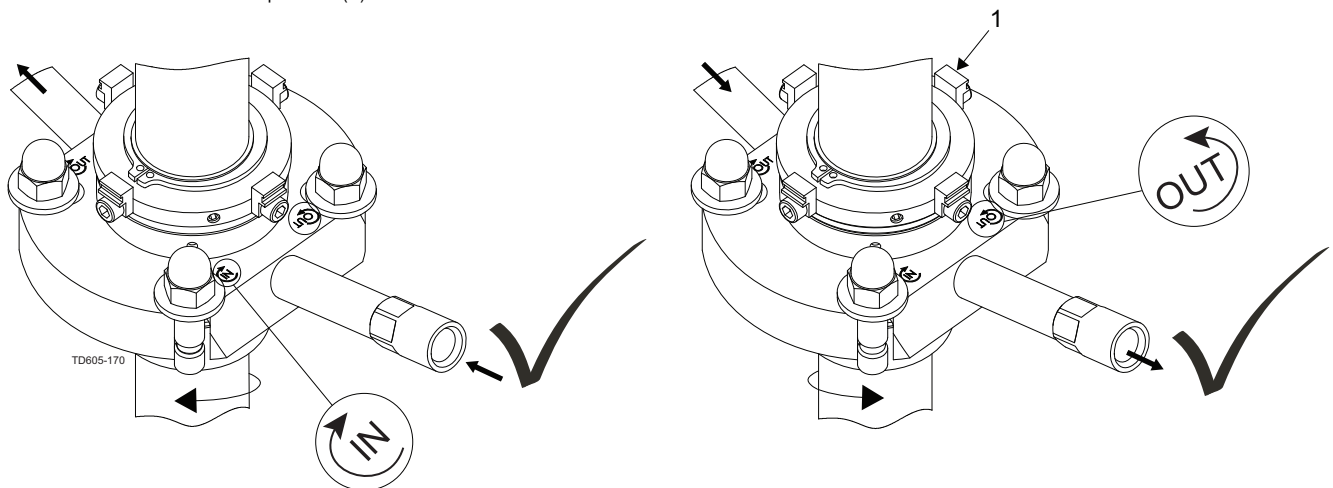

NOTE

Alfa Laval recommends installing a pressure relief valve to ensure pressure never exceed specifications.
Alfa Laval recommends installing a non-return valve onto the inlet connection, to ensure that the seal never runs dry.
If higher flushing pressure is desired, please contact Alfa Laval for advice.

6 Technical data

All dimensions in mm unless otherwise stated.

6.6 Tightening torques for bolt connections

CAUTION

Use Loctite® before fastening.
Do NOT use air powered tools.

M4	M5	M6	M8	M10	M12	M14	M16	M18	M20	M22	M24
3Nm	6Nm	11Nm	26Nm	51Nm	88Nm	141Nm	218Nm	308Nm	439Nm	582Nm	724Nm

All dimensions in mm unless otherwise stated.

6.7 Shaft alignment

Shaft to be aligned in bearing frame or in gear motor.

RPM up to:	50	100	500	1000	2800
U (max radial tolerance, ALS/ALB)	0.4	0.3	0.2	0.1	0.05

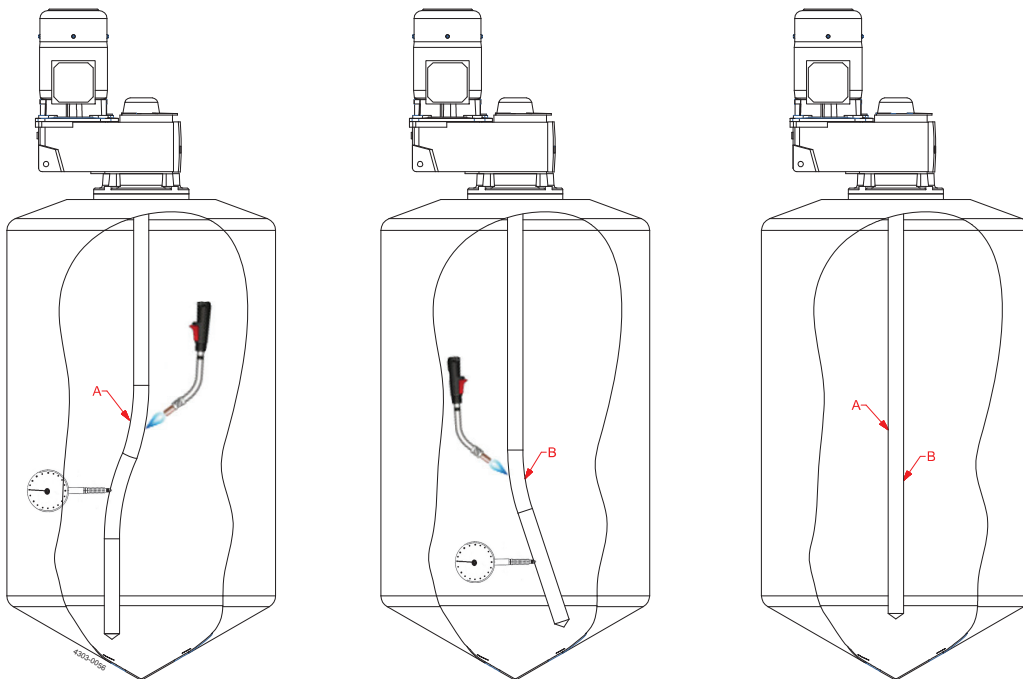
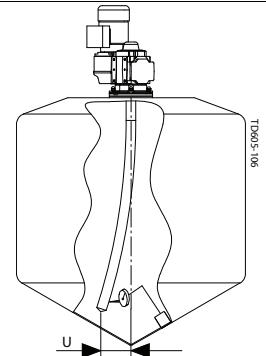

After propellers has been welded onto the shaft and / or two shaft parts has been welded together - the shaft must be aligned. If the shafts has been welded according to Alfa Laval's recommendations shown below – the required alignment will be very little as the amount of introduced heat to the shaft is minimized and due to the fact that all shafts has been aligned before delivery from Alfa Laval.

“All-weld shaft connections and propellers to shaft with one welding seam at a time, cool with air and continue with one welding until welding is according to illustration. Use welding procedures which introduce as less heat, tension and bending to the shaft as possible.”

Required tool:

1. A gas-welding torch supplied with a mixture of Acetylene and Oxygen gas.
2. A dial indicator.

6 Technical data

All dimensions in mm unless otherwise stated.

Procedure:

1. Alignment of the shaft is carried out in steps from the bearing frame / gear motor and down to the shaft end.
 2. If the shaft has been exposed to uneven heat around "A" (due to welding of shaft connection or welding of propeller onto shaft) a possible bend can be introduced around "A".
 3. The dial indicator is located about 500-2000 mm below "A" (but above the next bend "B") and the shaft is rotated until the shaft is pointing to the left as shown on the picture.
 4. The welding torch is used on the opposite site of the bend (the right side of the shaft in this example) about 25-50 mm further up or down from the welding area "A". The welding torch is positioned very near the shaft surface without moving it and the surface of the shaft is rapidly heated up (1-10 seconds depending on shaft bend) until a Ø2-10 mm red spot is observed. Observing the dial indicator the shaft will, during the heating process, bend even more to the wrong direction but during cooling it bends back to a "more" align position.
 5. The shaft is cooled down with compressed air until the temperature of the part of the shaft around A is the same as the rest of the shaft and the surrounding temperature (2-10 minutes depending on amount of heat introduced).
 6. Step 3), 4) and 5) are repeated until the alignment is according the specified "U" (which is a function of speed and Agitator type).
 7. The next position "B" where the shaft has been exposed to uneven heat is located (due to welding of shaft connection or welding of propeller onto shaft).
 8. The dial indicator is located 500-2000 mm below "B" (but above the next bend) or at the shaft end if the shaft does not have any other bends and the shaft is rotated until the shaft is pointing to the right as shown on the picture.
 9. The welding torch is used on the opposite site of the bend (the left side of the shaft in this example) about 25-50 mm further up or down from the welding area. The welding torch is positioned very near shaft surface without moving it and the surface of the shaft is rapidly heated up (1-10 seconds depending on shaft bend) until a Ø2-10 mm red spot is observed.
 10. The shaft is cooled down with compressed air until the temperature of the part of the shaft around A is the same as the rest of the shaft and the surrounding temperature (2-10 minutes depending on amount of heat introduced).
 11. Step 8), 9) and 10) are repeated until the alignment is according the specified "U" (which is a function of speed and Agitator type).
 12. The spot areas where the shaft has been heated and aligned using the welding torch must be cleaning using chemical pickling and or mechanical abrasive polishing.
-

All dimensions in mm unless otherwise stated.

6.8 Spider coupling

Axial alignment and tooth thickness [mm]:

	Bearing frame type:				
	BC160/35 BC160D/30 BC160DH/30	B20 B25 B25/30	B35 B35/40	B45 B45/50	B55 B55/60
X:	2	2	2.5	3	3.5
Ynew:	8.5	8.5	10.9	13.3	17.7
Ymin:	5.6	5.6	7.9	10.3	13.7

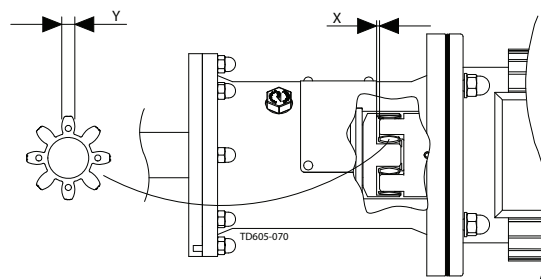

CAUTION

During check of spider ensure that all dust is removed before reassembly.

6.9 Storage

Store the Agitator in dry and clean environments.

Rotate shaft every second week to ensure seal faces do not stick together.

7 Parts lists and drawings, service kits and tools

Agitator type ALS / ALB, main components - drive end

7.1 Agitator main components, drive end

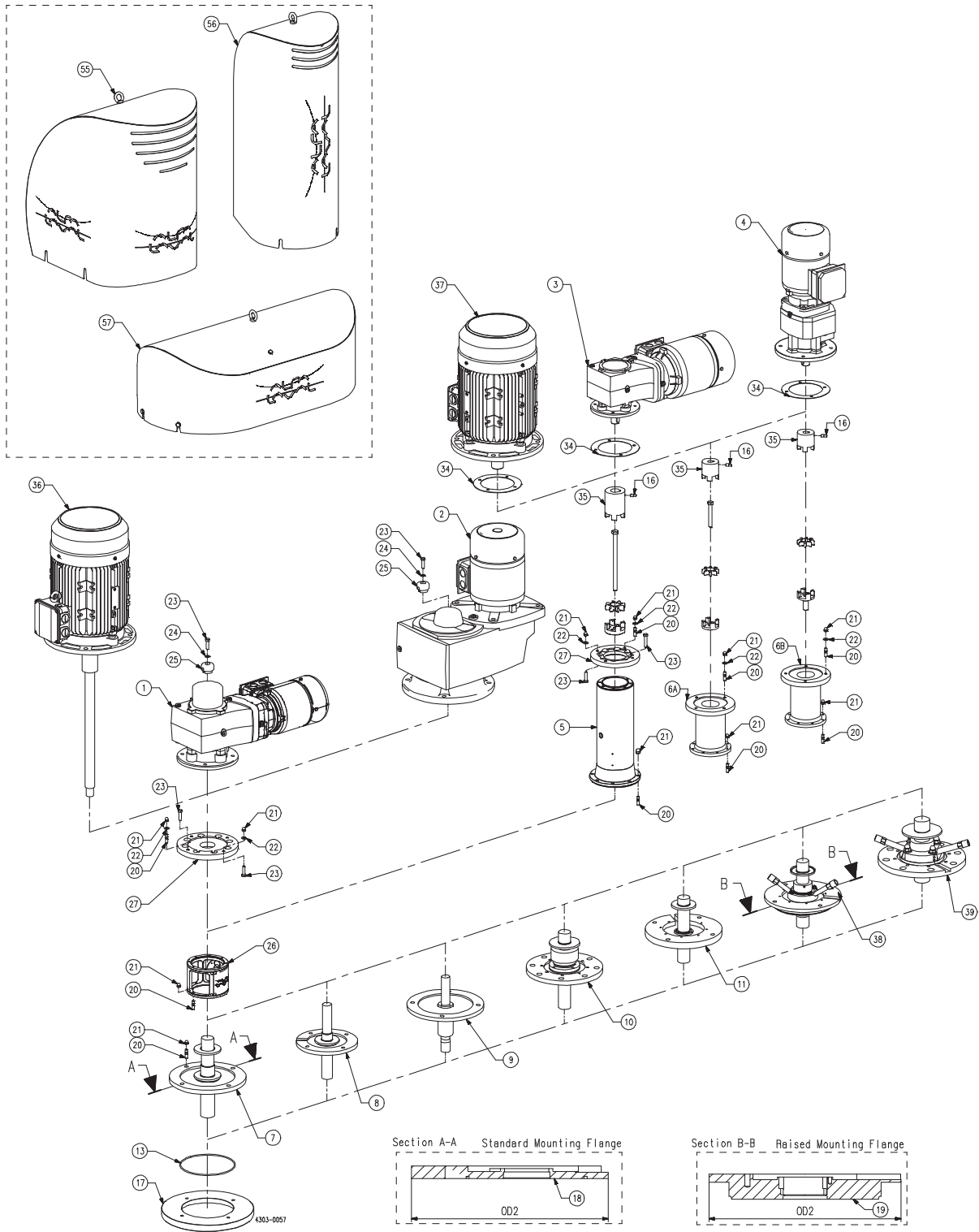

7 Parts lists and drawings, service kits and tools

Agitator type ALS / ALB, main components - drive end

Parts list

Pos.		Qty	Denomination
1	□	1	GR gear motor, hollow shaft
2	□	1	GP gear motor, hollow shaft
3	□	1	GR gear motor, output shaft
4	□	1	GC gear motor, output shaft
5	◆	1	Bearing frame B20, B25, B25/30, B35, B35/40, B45, B45/50, B55, B55/60
6	◆	1	Bearing frame, BC160/35, BC160D/30, BC160DH/30
7	◆	1	Shaft seal type R
8	◆	1	Shaft seal type G
9	◆	1	Shaft seal type V
10	◆	1	Shaft seal type S
11	◆	1	Shaft seal type S3
13		1	O-ring
16	□	X	Screw
17	□	1	Welding flange
18	□	1	Mounting flange, standard
19	□	1	Mounting flange, raised
20	□	X	Stud
21	□	X	Cap nut
22	□	X	Washer
23	□	X	Screw
24	□	1	Washer, Nord Lock
25	□	1	Fixing element
26	□	1	Lantern, complete
27	□	1	Drive unit flange
34	□	1	Flat gasket
35	□	1	Coupling
36	□	1	Motor and shaft unit
37	□	1	Motor
38	◆	1	Shaft seal type D
39	◆	1	Shaft seal type DC

□ Article number available upon request by serial number or article number of the Agitator.

◆ Article number is to be found in the Spare part manual ESE03339, available from the on-line Alfa Laval product catalogue Anytime or the Close at hand spare part catalogue.

X Quantity may vary depending on Agitator type, will be informed upon request.

7 Parts lists and drawings, service kits and tools

Agitator type ALS / ALB, main components - wet end

7.2 Agitator main components, wet end

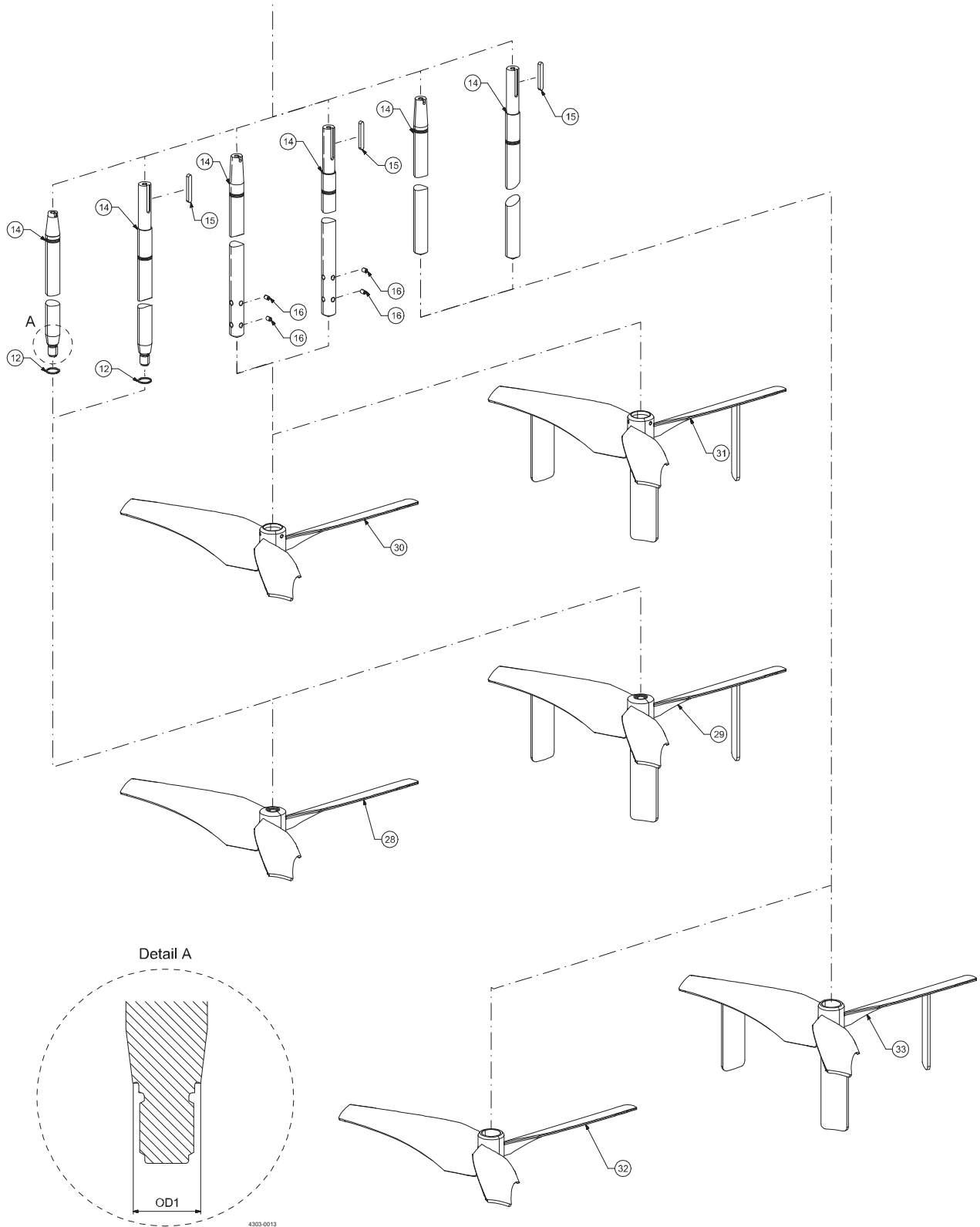

7 Parts lists and drawings, service kits and tools

Agitator type ALS / ALB, main components - wet end

Parts list

Pos.	Qty	Denomination
12	1	O-ring
14 <input type="checkbox"/>	1	Shaft
15 <input type="checkbox"/>	1	Parrallel key
16 <input type="checkbox"/>	X	Screw, pointed
28 <input type="checkbox"/>	1	Impeller device, EnSaFoil, (ESF), w. thread
29 <input type="checkbox"/>	1	Impeller device, EnSaFoil Low level, (ESFL), w. thread
30 <input type="checkbox"/>	1	Impeller device, EnSaFoil, (ESF), w. screws
31 <input type="checkbox"/>	1	Impeller device, EnSaFoil Low level, (ESFL), w. screws
32 <input type="checkbox"/>	1	Impeller device, EnSaFoil, (ESF), welding
33 <input type="checkbox"/>	1	Impeller device, EnSaFoil Low level, (ESFL), welding

Article number available upon request by serial number or article number of the Agitator.

◆ Article number is to be found in the Spare part manual ESE03339, available from the on-line Alfa Laval product catalogue Anytime or the Close at hand spare part catalogue.

X Quantity may vary depending on Agitator type, will be informed upon request.

7 Parts lists and drawings, service kits and tools

Bearing frame, B20, B25, B25/30, B35, B35/40, B45, B45/50, B55, B55/60

7.3 Bearing frame, B20, B25, B25/30, B35, B35/40, B45, B45/50, B55, B55/60

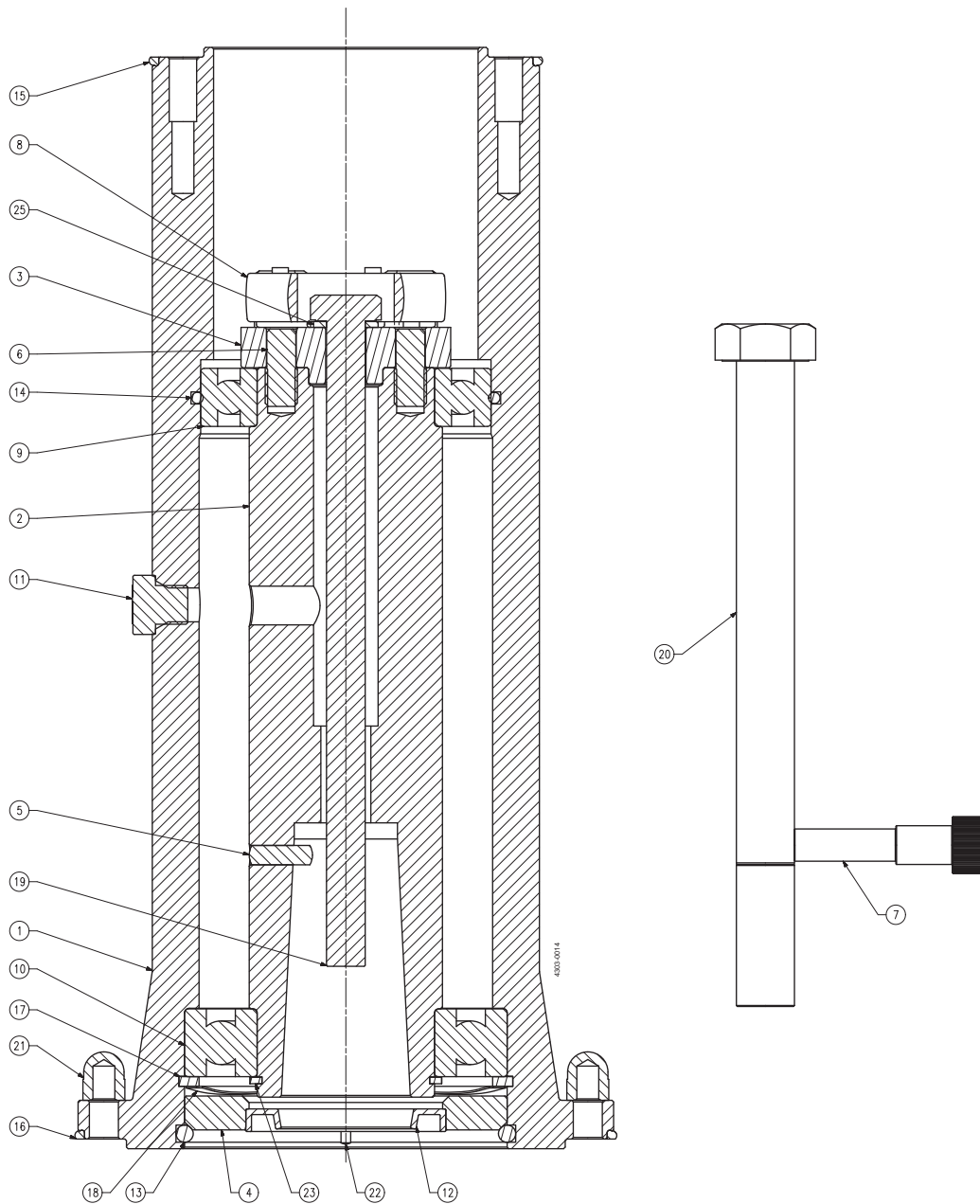

7 Parts lists and drawings, service kits and tools

Bearing frame, B20, B25, B25/30, B35, B35/40, B45, B45/50, B55, B55/60

Parts list

Pos.	Qty	Denomination
1	1	Bearing frame - housing
2	1	Drive shaft
3	1	Coupling
4	1	Cover
5	1	Pin
6	2	Pin
7	1	Tool, retainer bolt
8	<input type="checkbox"/>	Spider
9	<input type="checkbox"/>	Bearing
10	<input type="checkbox"/>	Bearing
11	<input type="checkbox"/>	PreVent Valve
12	<input type="checkbox"/>	Seal, radial
13	<input type="checkbox"/>	O-ring
14	<input type="checkbox"/>	O-ring
15	<input type="checkbox"/>	O-ring
16	<input type="checkbox"/>	O-ring
17	1	Circlip, inner
18	1	Spring, wave
19	1	Screw
20	1	Extractor bolt
21	8	Cap nut
22	2	Pin
23	1	Circlip, outer
25	1	Washer

Service kits

Denomination	B20	B25	B25/30	B35
--------------	-----	-----	--------	-----

Assembly Kit

<input type="checkbox"/>	Assembly Kit, Bearing frame B20, B25, B25/30, B35	TE261301266B	TE261301267B	TE2613066880	TE261301269C
--------------------------	---	-------	--------------	--------------	--------------	--------------

NOTE

Article numbers are to be found in the Spare part manual ESE03339, available from the on-line Alfa Laval product catalogue Anytime or the Close at hand spare part catalogue.

7 Parts lists and drawings, service kits and tools

Bearing frame, B20, B25, B25/30, B35, B35/40, B45, B45/50, B55, B55/60

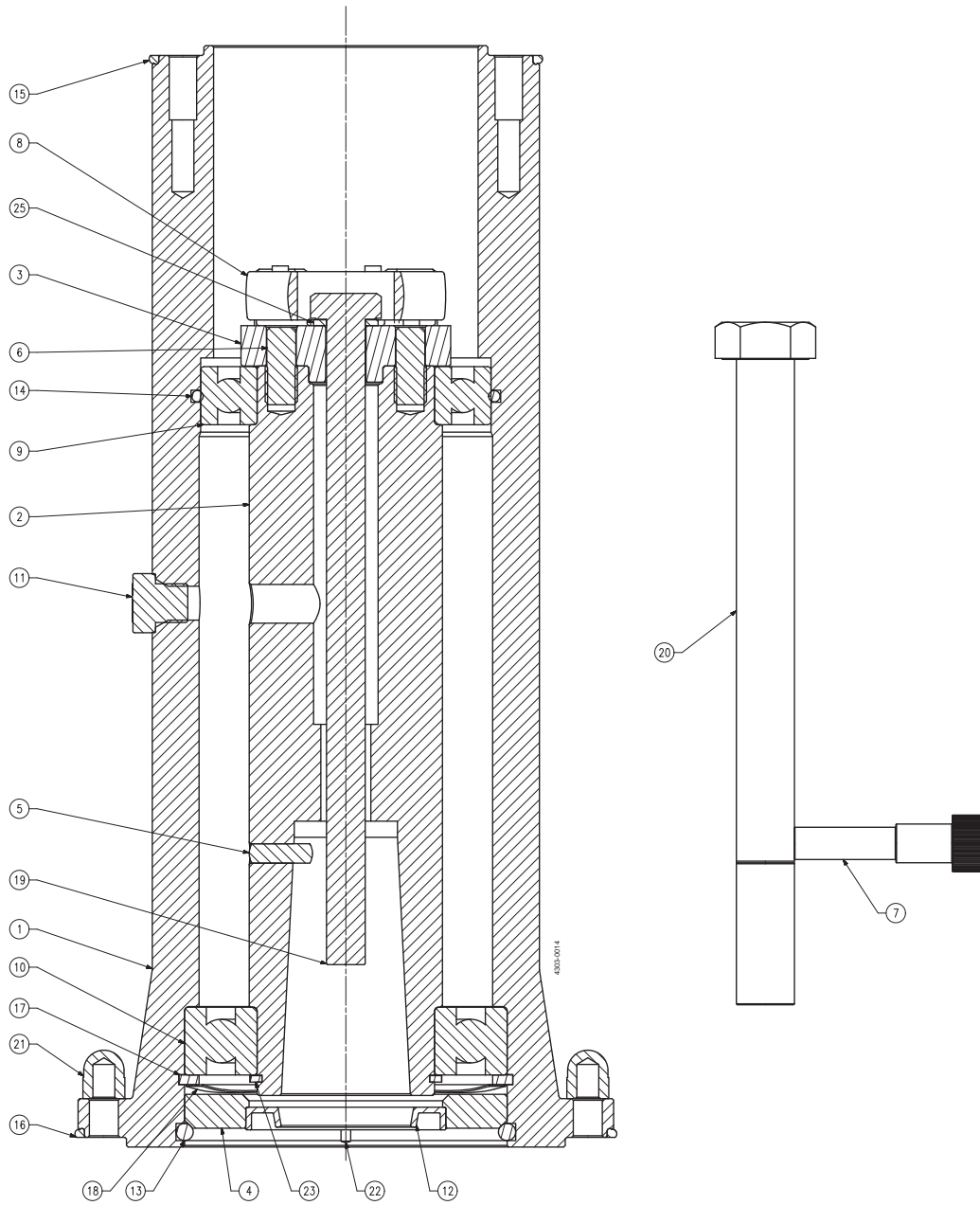

7 Parts lists and drawings, service kits and tools

Bearing frame, B20, B25, B25/30, B35, B35/40, B45, B45/50, B55, B55/60

Parts list

Pos.	Qty	Denomination
1	1	Bearing frame - housing
2	1	Drive shaft
3	1	Coupling
4	1	Cover
5	1	Pin
6	2	Pin
7	1	Tool, retainer bolt
8	<input type="checkbox"/>	Spider
9	<input type="checkbox"/>	Bearing
10	<input type="checkbox"/>	Bearing
11	<input type="checkbox"/>	PreVent Valve
12	<input type="checkbox"/>	Seal, radial
13	<input type="checkbox"/>	O-ring
14	<input type="checkbox"/>	O-ring
15	<input type="checkbox"/>	O-ring
16	<input type="checkbox"/>	O-ring
17	1	Circlip, inner
18	1	Spring, wave
19	1	Screw
20	1	Extractor bolt
21	8	Cap nut
22	2	Pin
23	1	Circlip, outer
25	1	Washer

Service kits

Denomination	B35/40	B45	B45/50	B55	B55/60
--------------	--------	-----	--------	-----	--------

Assembly Kit

<input type="checkbox"/>	Assembly Kit, Bearing frame B35/40, B45, B45/50, B55, B55/60	TE261304566B	TE261301100B	TE261305434A	TE261301102B	TE2613065530
--------------------------	--	--------------	--------------	--------------	--------------	--------------

NOTE

Article numbers are to be found in the Spare part manual ESE03339, available from the on-line Alfa Laval product catalogue Anytime or the Close at hand spare part catalogue.

7 Parts lists and drawings, service kits and tools

Bearing frame BC160/35, BC160D/30, BC160DH/30

7.4 Bearing frame BC160/35, BC160D/30, BC160DH/30

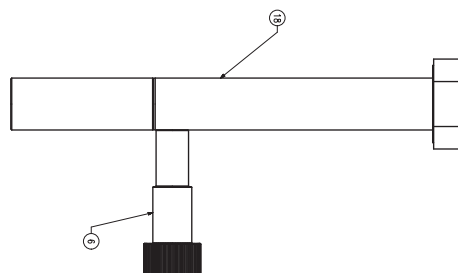
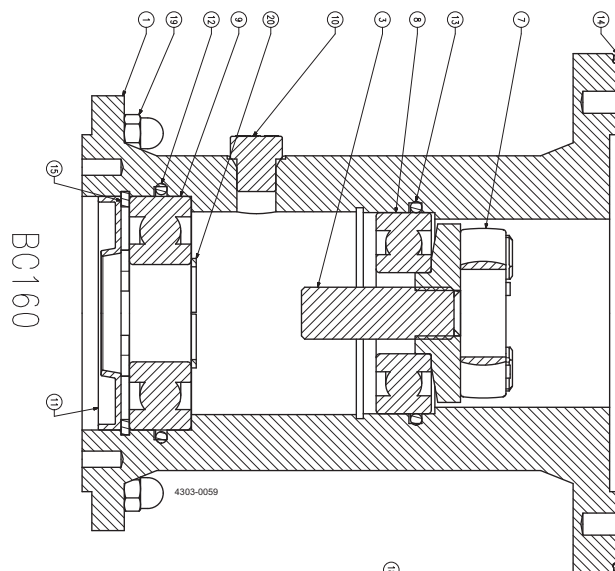
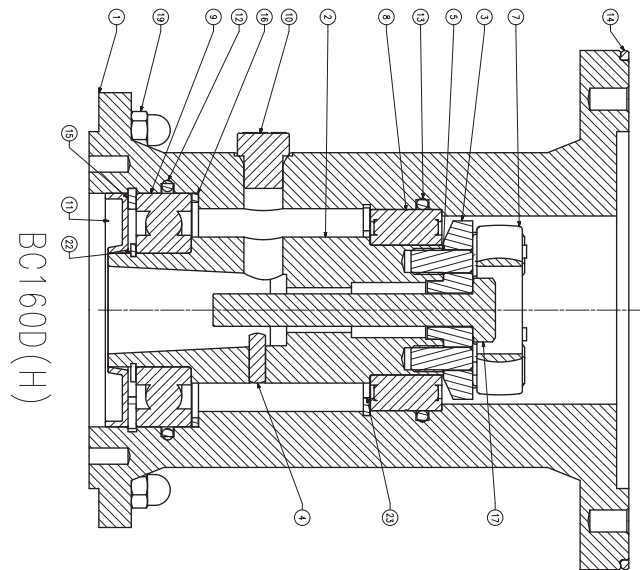

7 Parts lists and drawings, service kits and tools

Bearing frame BC160/35, BC160D/30, BC160DH/30

Parts list

Pos.	Qty	Denomination
1	1	Bearing frame - housing
2	1	Drive shaft
3	1	Coupling
4	1	Pin
5	2	Pin
6	1	Tool, retainer bolt
7	<input type="checkbox"/>	Spider
8	<input type="checkbox"/>	Bearing
9	<input type="checkbox"/>	Bearing
10	<input type="checkbox"/>	PreVent valve
11	<input type="checkbox"/>	Seal, radial
12	<input type="checkbox"/>	O-ring
13	<input type="checkbox"/>	O-ring
14	<input type="checkbox"/>	O-ring
15	1	Circlip, inner
16	1	Seeger ring
17	1	Screw
18	1	Extractor bolt
19	8	Cap nut
20	1	Circlip, outer
22	7	Circlip, outer
23	1	Circlip, inner

Service kits

Denomination	BC160/35 (right)	BC160/35 (left)	BC160D/30	BC160DH/30
--------------	---------------------	-----------------	-----------	------------

Assembly Kit

<input type="checkbox"/>	Assembly Kit, Bearing frame BC160/35, BC160D/30, BC160DH/30	TE261303783B	TE261303783B	TE261303672B	TE2613071680
--------------------------	---	--------------	--------------	--------------	--------------

NOTE

Article numbers are to be found in the Spare part manual ESE03339, available from the on-line Alfa Laval product catalogue Anytime or the Close at hand spare part catalogue.

7 Parts lists and drawings, service kits and tools

Shaft seal, type D

7.5 Shaft seal, type D

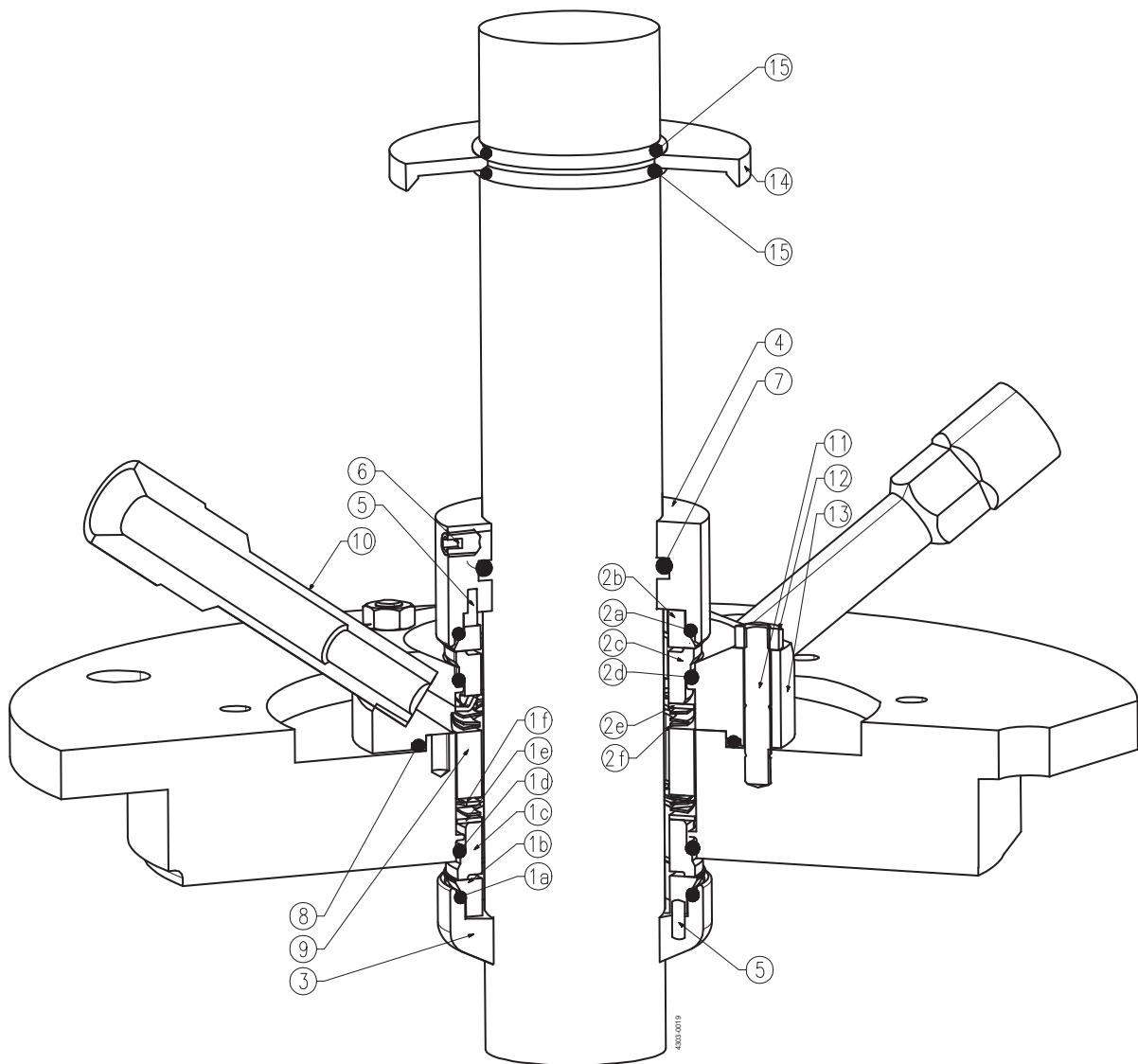

7 Parts lists and drawings, service kits and tools

Shaft seal, type D

Parts list

Pos.	Qty	Denomination
1	1	Seal
	1	Seal
	1	Seal
	1	Seal
2	1	Seal
	1	Seal
3	1	Ring, counter**
4	1	Ring, counter
5	4	Pin
6	1	Screw
7	1	O-ring
	1	O-ring
8	1	O-ring
	1	O-ring
9	1	Spacer
10	2	Flush, connection 1/2"-14 BSP
11	4	Stud
12	4	Nut
13	1	Seal housing
14	1	Oil trap
15	2	O-ring, FPM

Service kits

Denomination	Ø30	Ø40
Seal kits		
□ Seal Kit, D, C/SiC-C/SiC, FPM	TE2613000121	TE2613000122
◆ Seal Kit, D, C/SiC-C/SiC, EPDM	TE2613000123	TE2613000124
○ Seal Kit, D, SiC/SiC-C/SiC, FPM	TE2613000125	TE2613000126
★ Seal Kit, D, SiC/SiC-C/SiC, EPDM	TE2613000127	TE2613000128

**Pos. 3: Welded onto shaft - maintenance must be carried out by Alfa Laval.

NOTE

Article numbers are to be found in the Spare part manual ESE03339, available from the on-line Alfa Laval product catalogue Anytime or the Close at hand spare part catalogue.

7 Parts lists and drawings, service kits and tools

Shaft seal, type DC

7.6 Shaft seal, type DC

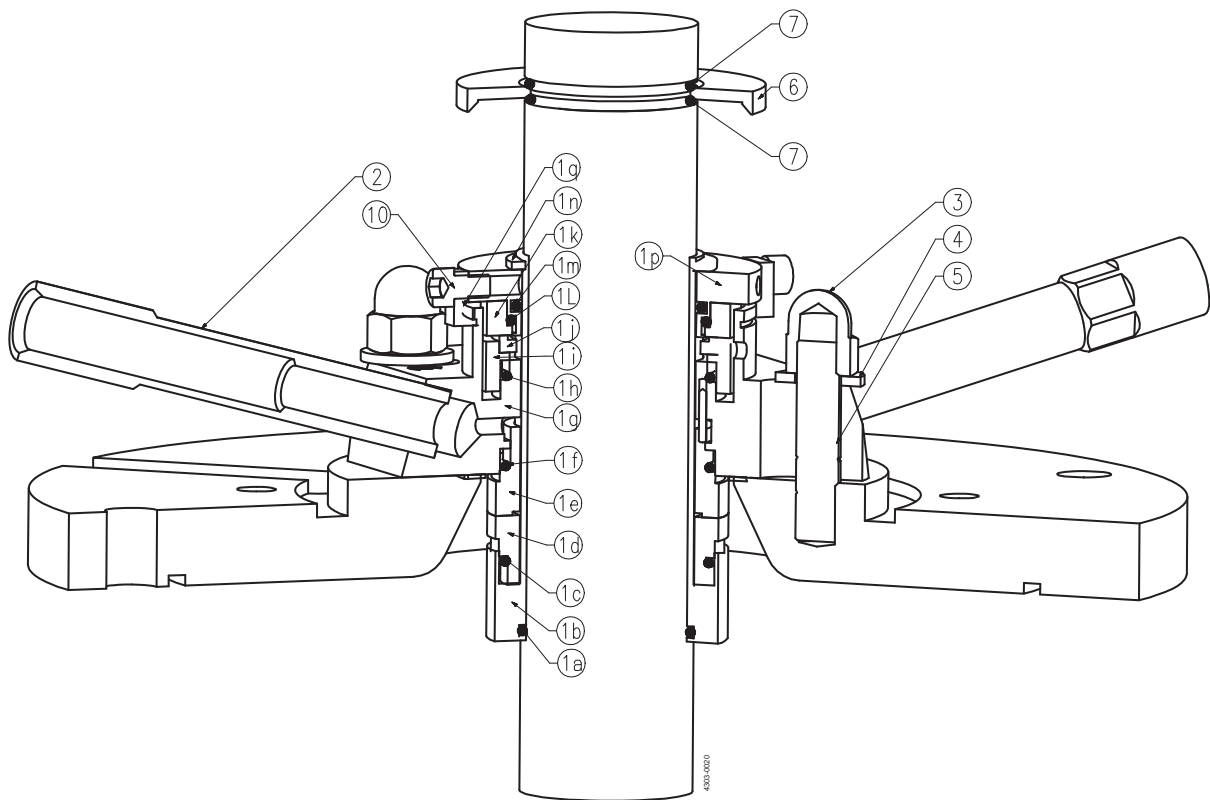

7 Parts lists and drawings, service kits and tools

Shaft seal, type DC

Parts list

Pos.		Qty	Denomination
1	□	1	DC seal
	◆	1	DC seal
	○	1	DC seal
	★	1	DC seal
2		2	Flush
3		4	Cap nut
4		4	Washer
5		4	Stud
6		1	Oil trap
7	□◆○★	2	O-ring

Service kits

Denomination	size: Ø30	size: Ø35	size: Ø40	size: Ø45
Seal kits				
□ Seal Kit, DC, C/SiC-C/SiC, EPDM	TE2613000137	TE2613000138	TE2613000139	TE2613000140
◆ Seal Kit, DC, C/SiC-C/SiC, FPM	TE2613000144	TE2613000145	TE2613000146	TE2613000147
○ Seal Kit, DC, SiC/SiC-C/SiC, EPDM	TE2613000151	TE2613000152	TE2613000153	TE2613000154
★ Seal Kit, DC, SiC/SiC-C/SiC, FPM	TE2613000158	TE2613000159	TE2613000160	TE2613000161

Parts list

Pos.		Qty	Denomination
1	□	1	DC seal
	◆	1	DC seal
	○	1	DC seal
	★	1	DC seal
2		2	Flush
6		1	Oil trap
7	□◆○★	2	O-ring

Service kits

Denomination	size: Ø50	size: Ø55	size: Ø60	size: Ø70
Seal kits				
□ Seal Kit, DC, C/SiC-C/SiC, EPDM	TE2613000141	TE2613000142	TE2613000143	9615478601
◆ Seal Kit, DC, C/SiC-C/SiC, FPM	TE2613000148	TE2613000149	TE2613000150	9615478701
○ Seal Kit, DC, SiC/SiC-C/SiC, EPDM	TE2613000155	TE2613000156	TE2613000157	9615478801
★ Seal Kit, DC, SiC/SiC-C/SiC, FPM	TE2613000162	TE2613000163	TE2613000164	9615478901

NOTE

Article numbers are to be found in the Spare part manual ESE03339, available from the on-line Alfa Laval product catalogue Anytime or the Close at hand spare part catalogue.

7 Parts lists and drawings, service kits and tools

Shaft seal type S1

7.7 Shaft seal, type S1

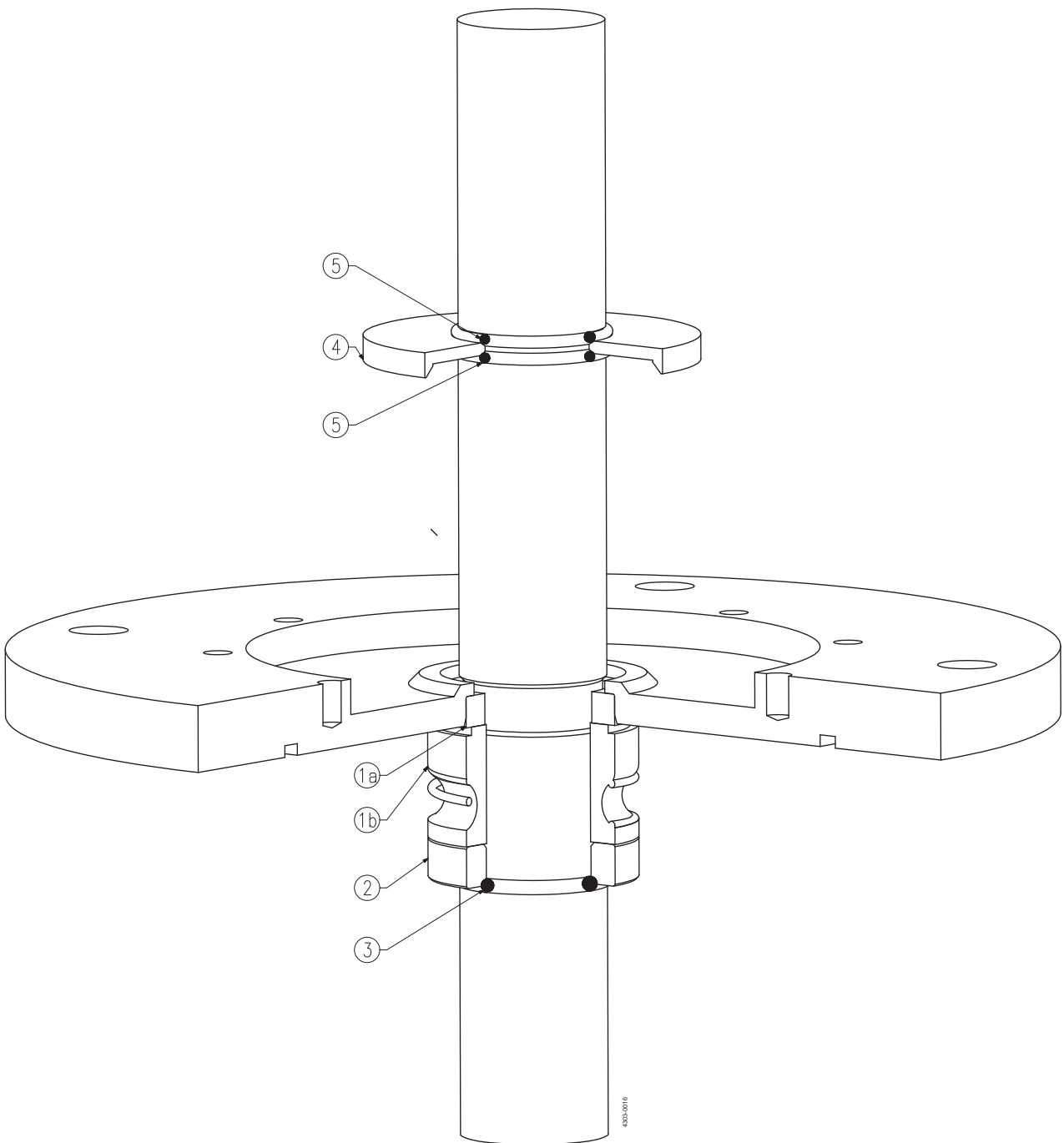

7 Parts lists and drawings, service kits and tools

Shaft seal type S1

Parts list

Pos.		Qty	Denomination
1	□	1	S1 seal
2		1	Ring, retainer
3	○★	1	O-ring, FPM
	□◆	1	O-ring, EPDM
4		1	Oil / Fluid trap
5	□◆○★	2	O-ring

Service kits

Denomination	size: Ø30	size: Ø35	size: Ø40	size: Ø45
Seal Kits				
□ Seal Kit, S1, SiC/SiC, EPDM	TE2613000050	TE2613000051	TE2613000052	TE2613000053
◆ Seal Kit, S1, C/SiC, EPDM	TE2613000054	TE2613000055	TE2613000056	TE2613000057
○ Seal Kit, S1, SiC/SiC, FPM	TE2613000058	TE2613000059	TE2613000060	TE2613000061
* Seal Kit, S1, C/SiC, FPM	TE2613000062	TE2613000063	TE2613000064	TE2613000065

NOTE

Article numbers are to be found in the Spare part manual ESE03339, available from the on-line Alfa Laval product catalogue Anytime or the Close at hand spare part catalogue.

7 Parts lists and drawings, service kits and tools

Shaft seal type S2

7.8 Shaft seal, type S2

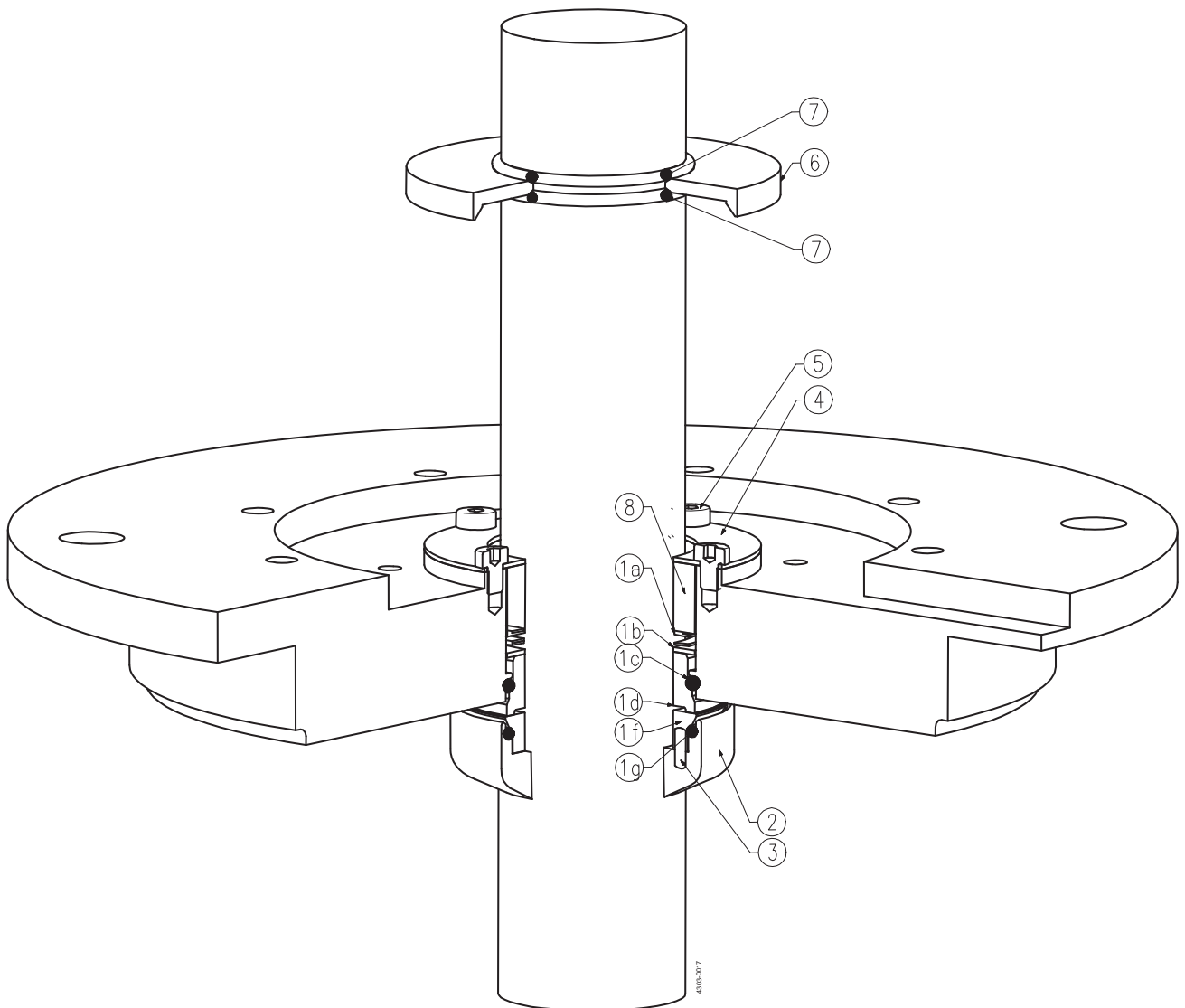

7 Parts lists and drawings, service kits and tools

Shaft seal type S2

Parts list

Pos.		Qty	Denomination
1	□	1	S2 seal
2		1	Ring, counter**
3		2	Pin
4		1	Ring, retainer
5		4	Screw
6		1	Oil / Fluid trap
7	□♦○*	2	O-ring, FPM
8		1	Spacer

Service kits

Denomination	size: Ø30	size: Ø40
Seal kits		
□ Seal Kit, S2, C/SiC, EPDM	TE2613000066	TE2613000068
♦ Seal Kit, S2, SiC/SiC, EPDM	TE2613000067	TE2613000069
○ Seal Kit, S2, C/SiC, FPM	TE2613000070	TE2613000072
* Seal Kit, S2, SiC/SiC, FPM	TE2613000071	TE2613000074

**Pos. 2: Welded onto shaft - maintenance must be carried out by Alfa Laval.

NOTE

Article numbers are to be found in the Spare part manual ESE03339, available from the on-line Alfa Laval product catalogue Anytime or the Close at hand spare part catalogue.

7 Parts lists and drawings, service kits and tools

Shaft seal, type S3

7.9 Shaft seal, type S3

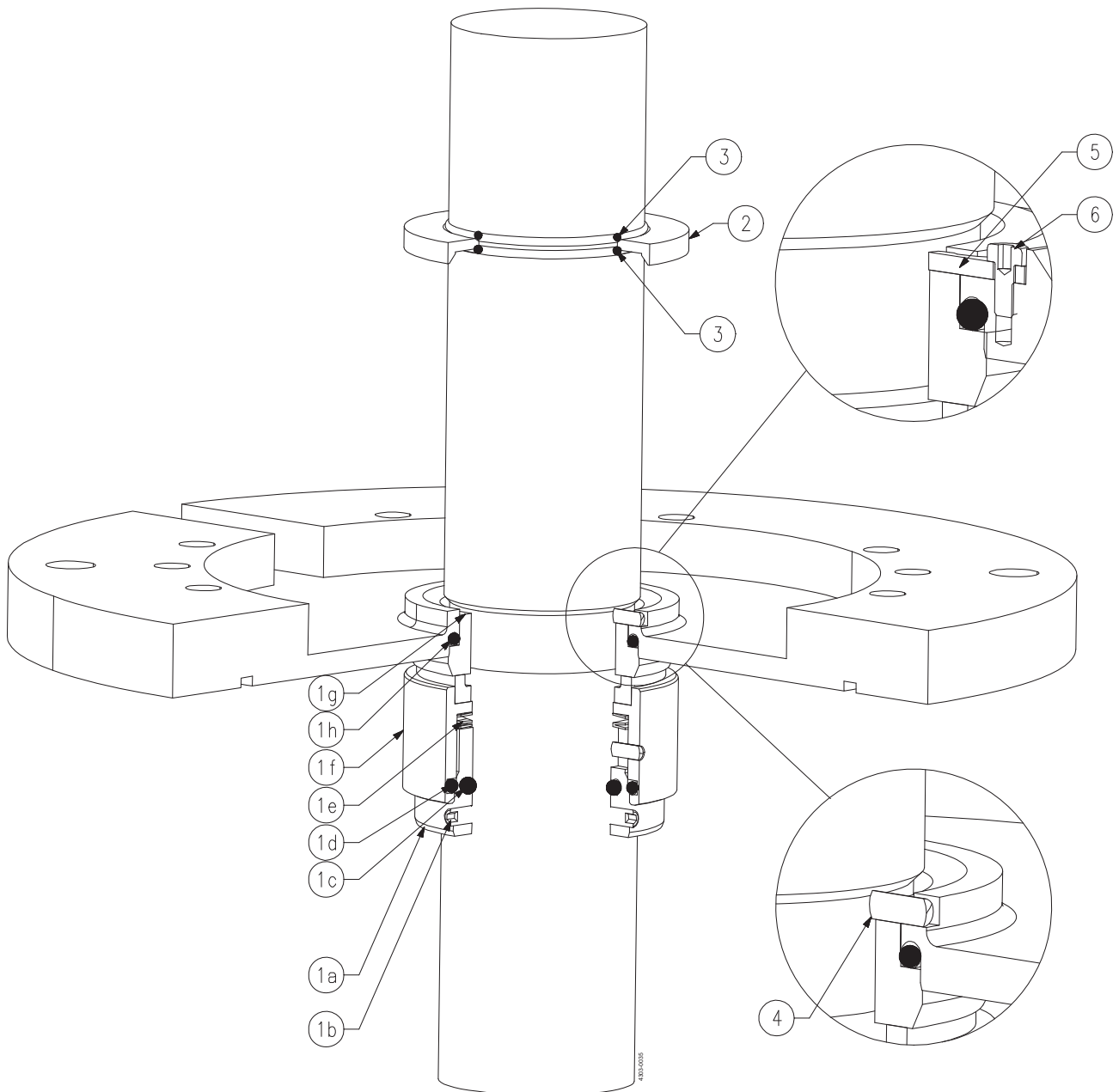

7 Parts lists and drawings, service kits and tools

Shaft seal, type S3

Parts list

Pos.		Qty	Denomination
1	□	1	S3 seal
	◆	1	S3 seal
2		1	Oil trap
3	□◆	2	O-ring
4		1	Locking pin
5		1	Locking plate
6		1	Screw

Service kits

Denomination	size: Ø30	size: Ø35	size: Ø40	size: Ø45
--------------	-----------	-----------	-----------	-----------

Seal Kits

□	Seal Kit, S3, C/SiC, EPDM	TE2613000087	TE2613000090	TE2613000091	TE2613000093
◆	Seal Kit, S3, C/SiC, FPM	TE2613000104	TE2613000106	TE2613000107	TE2613000108

Parts list

Pos.		Qty	Denomination
1	□	1	S3 seal
	◆	1	S3 seal
2		1	Oil trap
3	□◆	2	O-ring
4		1	Locking pin
5		1	Locking plate
6		1	Screw

Service kits

Denomination	size: Ø50	size: Ø55	size: Ø60	size: Ø65
--------------	-----------	-----------	-----------	-----------

Seal Kits

□	Seal Kit, S3, C/SiC, EPDM	TE2613000095	TE2613000096	TE2613000098	TE2613000099
◆	Seal Kit, S3, C/SiC, FPM	TE2613000109	TE2613000110	TE2613000112	TE2613000113

NOTE

Article numbers are to be found in the Spare part manual ESE03339, available from the on-line Alfa Laval product catalogue Anytime or the Close at hand spare part catalogue.

7 Parts lists and drawings, service kits and tools

Shaft seal, type S3

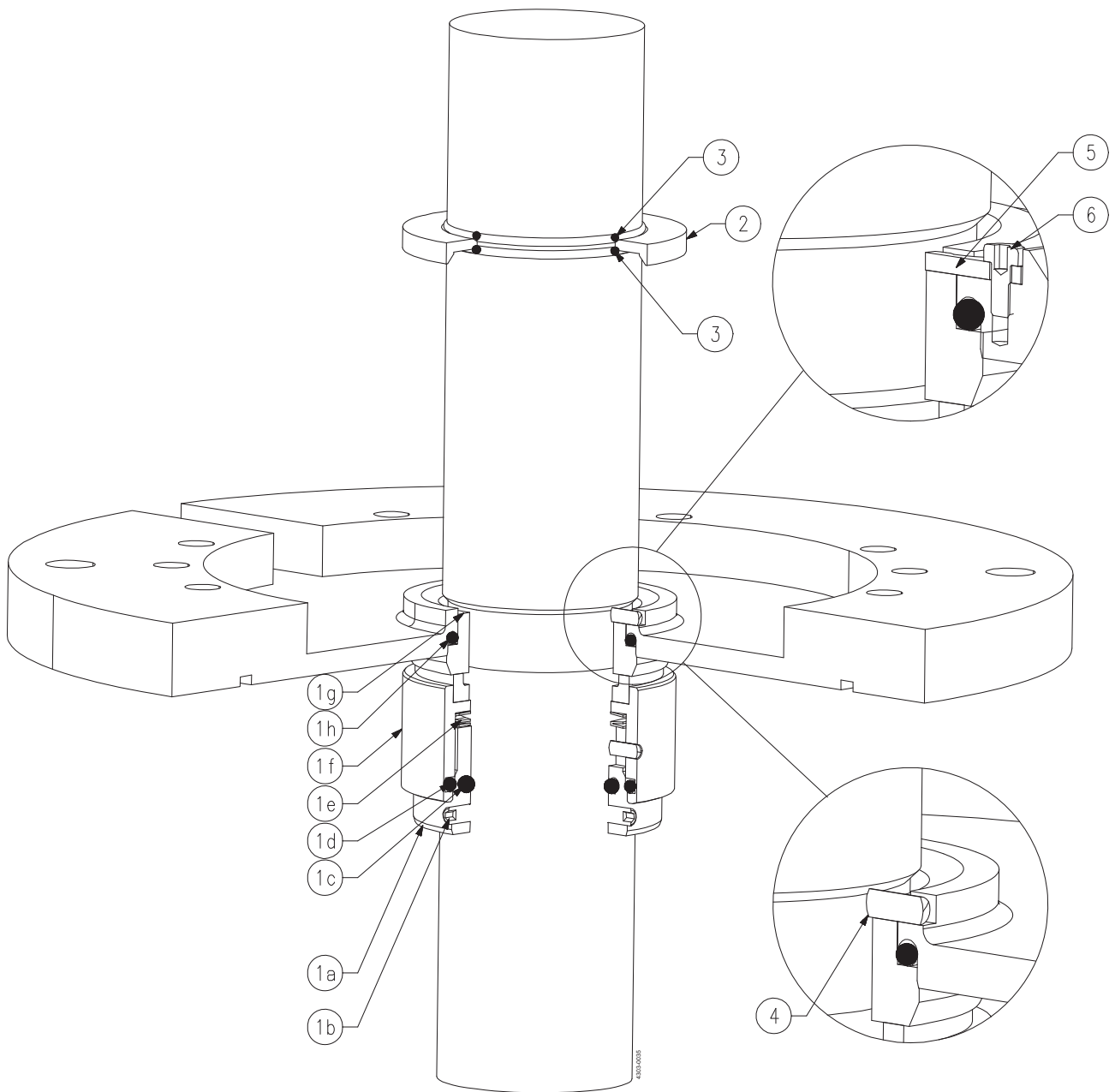

7 Parts lists and drawings, service kits and tools

Shaft seal, type S3

Parts list

Pos.		Qty	Denomination
1	□	1	S3 seal,
	◆	1	S3 seal
2		1	Oil trap
3	□◆	2	O-ring, FPM
4		1	Locking pin
5		1	Locking plate
6		1	Screw

Service kits

Denomination	size: Ø70	size: Ø75	size: Ø80	size: Ø90
--------------	-----------	-----------	-----------	-----------

Seal Kits

□ Seal Kit, S3, C/SiC, EPDM	TE2613000100	TE2613000101	TE2613000102	TE2613000103
◆ Seal Kit, S3, C/SiC, FPM	TE2613000116	TE2613000117	TE2613000118	TE2613000120

NOTE

Article numbers are to be found in the Spare part manual ESE03339, available from the on-line Alfa Laval product catalogue Anytime or the Close at hand spare part catalogue.

7 Parts lists and drawings, service kits and tools

Tools

7.10 Tools

Retainer bolt and extractor bolt for bearing frame

Pos	Denomination	BC160D(H)/30 Item no.	B25, B25/30 Item no.	B35, B35/40 Item no.	B45, B45/50 Item no.	B55, B55/60 Item no.
1	Retainer bolt	TE2604036760	TE2604010700	TE2604010100	TE2604010890	TE2604010900
2	Extractor bolt	TE2601000331	TE2601000331	TE2601000336	TE2601000334	TE2601000334

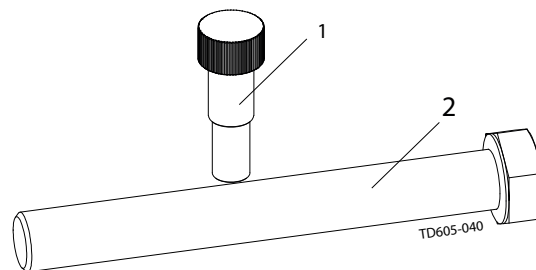

Appendix

8.1 Drive unit instructions

The drive unit is supplied by sub supplier and all important installation requirement is transferred to the Agitator instruction manual. For further information regarding maintenance and storage of the drive unit please find the drive unit instruction manual by below links

For Agitators with gears please find the drive unit instruction manual by below link:
https://www.nord.com/cms/en/documentation/manuals/details_1139/detail_42075.jsp

For Agitators with direct drive (motor only) please find the motor instruction manual by below link:
<http://www.hoyeremotors.com/Catalogues-30304.htm>

How to contact Alfa Laval

Contact details for all countries are continually updated on our website.

Please visit www.alfalaval.com to access the information directly.

© Alfa Laval Corporate AB

This document and its contents is owned by Alfa Laval Corporate AB and protected by laws governing intellectual property and thereto related rights. It is the responsibility of the user of this document to comply with all applicable intellectual property laws. Without limiting any rights related to this document, no part of this document may be copied, reproduced or transmitted in any form or by any means (electronic, mechanical, photocopying, recording, or otherwise), or for any purpose, without the expressed permission of Alfa Laval Corporate AB. Alfa Laval Corporate AB will enforce its rights related to this document to the fullest extent of the law, including the seeking of criminal prosecution.